



Seagrass-Watch

Proceedings of a workshop for monitoring
seagrass habitats in the Noosa region,
South East Queensland

*CWA Hall, Tewantin
9 - 10 March 2013*

Len McKenzie & Rudi Yoshida

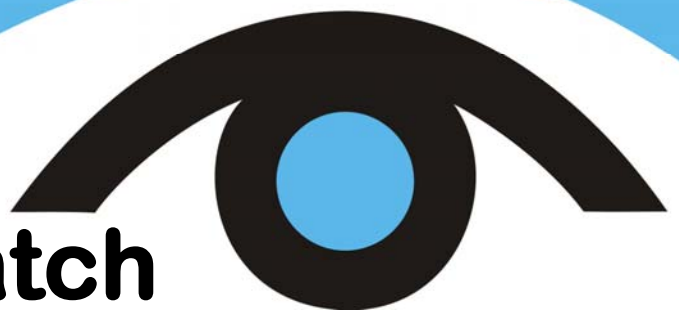

First Published 2013

©Seagrass-Watch HQ, 2013

Copyright protects this publication.

Reproduction of this publication for educational or other non-commercial purposes is authorised without prior written permission from the copyright holder provided the source is fully acknowledged.

Reproduction of this publication for resale or other commercial purposes is prohibited without prior written permission of the copyright holder.

Disclaimer

Information contained in this publication is provided as general advice only. For application to specific circumstances, professional advice should be sought.

Seagrass-Watch HQ has taken all reasonable steps to ensure the information contained in this publication is accurate at the time of the survey. Readers should ensure that they make appropriate enquires to determine whether new information is available on the particular subject matter.

The correct citation of this document is

McKenzie, LJ & Yoshida, R.L. (2013). Seagrass-Watch: Proceedings of a workshop for monitoring seagrass habitats in the Noosa region, South East Queensland. CWA Hall, Tewantin, Queensland, 9 - 10 March 2013 (Seagrass-Watch HQ, Cairns). 50pp.

Produced by Seagrass-Watch HQ

Front cover photos (left to right): monitoring Keyser channel (Feb13) by Maree Cliff; *Zostera capricorni* underwater by Rudi Yoshida; and *Zostera* meadow Keyser Island (Nov13) by Len McKenzie.

Enquires should be directed to:

Len McKenzie
Seagrass-Watch Program Leader
Seagrass-Watch HQ
TropWATER (James Cook University)
PO Box 6811
Cairns QLD 4870 AUSTRALIA



Table of Contents

OVERVIEW	5
WORKSHOP LEADERS	7
AGENDA - LEVEL 1 (BASIC)	8
SATURDAY 9 TH MARCH 2013 (CWA HALL, TEWANTIN)	8
SUNDAY 10 TH MARCH 2013 (KEYSER ISLAND)	8
BACKGROUND	9
INTERESTING FACTS:	17
SEAGRASS IN THE NOOSA REGION OF SOUTH EAST QUEENSLAND	19
A GUIDE TO THE IDENTIFICATION OF SOUTH EAST QUEENSLAND’S SEAGRASSES ..	21
PARTS OF A SEAGRASS PLANT	23
MONITORING A SEAGRASS MEADOW	25
MONITORING SEAGRASS	26
SEAGRASS-WATCH.....	26
EACH SAMPLING EVENT.....	29
AT COMPLETION OF MONITORING	30
HOW TO USE A COMPASS	33
MAKING A HERBARIUM PRESS SPECIMEN	36
<i>COLLECTION</i>	36
<i>PRESSING</i>	36
<i>HERBARIA</i>	38
UNDERSTANDING SEDIMENT	39
MANAGING SEAGRASS RESOURCES	41
THREATS TO SEAGRASS HABITATS	41
MANAGEMENT	41
REFERENCES	44



CWA Hall, 123 Poinciana Avenue, Tewantin

Telephone: 07-5449 9650

Overview

Seagrass-Watch is a participatory monitoring program developed in 1998 to provide an early warning of coastal ecological decline. Anyone can participate in Seagrass-Watch, as it responds to local needs. Program participants include scientists, rangers and volunteers (e.g., local residents, indigenous groups, tertiary institutions, non-government organisations). Seagrass-Watch is a monitoring program that brings people together for seagrass conservation. Participants range in ages from 18 to 68 and represent a diverse cross-section of the community, including tradespeople, engineers, school teachers, fishers, divers, retirees, high school and university students, biologists and ecologists. Many are involved with local environmental groups and have a keen interest in conservation and environmental issues.

Seagrass-Watch is a global scientific, non-destructive, seagrass assessment and monitoring program. It identifies areas important for seagrass species diversity and conservation. The information collected can be used to assist the management of coastal environments and to prevent significant areas and species being lost.

Monitoring seagrass resources is important for two reasons: it is a valuable tool for improving management practices; and it allows us to know whether resource status and condition is stable, improving or declining. Successful management of coastal environments (*including seagrass resources*) requires regular monitoring of the status and condition of natural resources.

Early detection of change allows coastal management agencies to adjust their management practices and/or take remedial action sooner for more successful results. Monitoring is important in improving our understanding of seagrass resources and to coastal management agencies for:

- *exposing coastal environmental problems before they become intractable,*
- *developing benchmarks against which performance and effectiveness can be measured,*
- *identifying and prioritising future requirements and initiatives,*
- *determining the effectiveness of management practices being applied,*
- *maintaining consistent records so that comparisons can be made over time,*
- *developing within the community a better understanding of coastal issues,*
- *developing a better understanding of cause and effect in land/catchment management practices,*
- *assisting education and training, and helping to develop links between local communities, schools and government agencies, and*
- *assessing new management practices.*

Seagrass-Watch monitoring efforts are vital to assist with tracking global patterns in seagrass health, and assess the human impacts on seagrass meadows, which have the potential to destroy or degrade these coastal ecosystems and decrease their yield of natural resources. Responsive management based on adequate information will help to prevent any further significant areas and species being lost. To protect the valuable seagrass meadows along our coasts, everyone must work together.

The goals of the Seagrass-Watch program are:

- *to educate the wider community on the importance of seagrass resources*
- *to raise awareness of coastal management issues*
- *to build the capacity of local stakeholders in the use of standardised scientific methodologies*
- *to conduct long-term monitoring of seagrass & coastal habitat condition*
- *to provide an early warning system of coastal environment changes for management*
- *to support conservation measures which ensure the long-term resilience of seagrass ecosystems.*

This workshop is coordinated by Maree Cliff and supported by the Noosa Integrated Catchment Association Inc, Caring for our Country, Noosa Biosphere Ltd, and Seagrass-Watch HQ (JCU). This workshop is for experienced participants who plan to lead seagrass monitoring at a site/location or conduct seagrass extension activities.

As part of the Level 1 workshop we will:

1. *study seagrass biology;*
2. *learn seagrass taxonomy;*
3. *discuss the present knowledge of seagrass ecology, including importance and threats;*
4. *gain knowledge of monitoring;*
5. *learn about the Seagrass-Watch program and techniques for monitoring seagrass resources; and*
6. *become skilled at conducting a Seagrass-Watch field monitoring event.*

The following information is provided as a training guide and a reference for future Seagrass-Watch monitoring activities. For further information, please do not hesitate to contact us at

Seagrass-Watch HQ

Centre for Tropical Water & Aquatic Ecosystem Research (TropWATER)

James Cook University

PO Box 6811

Cairns QLD 4870

AUSTRALIA

E-mail hq@seagrasswatch.org

or visit

www.seagrasswatch.org



Photo: Jurgen Freund.

Workshop leaders



Len McKenzie

Len is a Principal Researcher with TropWATER (James Cook University) and Seagrass-Watch Program Leader. He is also the Task Leader of the Reef Rescue Marine Monitoring Program – Intertidal Seagrass Monitoring and project leader for a series of projects involving the assessment and sustainable use of coastal fisheries habitats. Len has over 20 years experience as a researcher on seagrass ecology, assessment and fisheries habitats. This includes experience within Australia and internationally in seagrass research, resource mapping/ assessment and biodiversity. He has provided information on seagrass communities that has been vital in management of seagrass resources of the Great Barrier Reef and at the state, national and international levels. He has also advised on fisheries and coastal resource-use issues for managers, fishing organisations, conservation and community groups. Len is a qualified trainer and assessor (TAE40110). Len is also the Secretary of the World Seagrass Association.

Current Projects

- Seagrass-Watch
- Status and mapping of seagrass resources in Queensland
- Condition, trend and risk in coastal habitats: Seagrass indicators, distribution and thresholds of potential concern
- Identification of indicators and thresholds of concern for water quality and ecosystem health on a bioregional scale for the Great Barrier Reef
- Assessment of primary and secondary productivity of tropical seagrass ecosystems
- Investigations on the macrofauna associated with seagrass meadows
- Great Barrier Reef Water Quality Protection Plan – Reef Rescue Marine Monitoring Program: seagrass



Rudi Yoshida

Rudi is a Research Assistant with TropWATER (James Cook University). Rudi has over 15 years experience in seagrass related research and monitoring. He is also a core member of Seagrass-Watch HQ, and ensures data submitted is managed and QA/QC protocols applied. He is also responsible for maintenance of the Seagrass-Watch website.

Current Projects

- Seagrass-Watch
- Great Barrier Reef Water Quality Protection Plan – Reef Rescue Marine Monitoring Program: seagrass



Agenda - Level 1 (*basic*)

Saturday 9th March 2013 (CWA Hall, Tewantin)

Morning	0900 - 0915 (15min)	Welcome & Introduction
	0915 - 0935 (20min)	Seagrass Biology and Identification*
	0935 - 1015 (40min)	Classroom activity: seagrass Identification
	1015 - 1030 (15min)	<i>Break</i>
	1030 - 1115 (60min)	Seagrass Identification <i>continued</i> *
	1115 - 1230 (60min)	Seagrass Biology 2 and Ecology
Afternoon	1230 - 1315	<i>Lunch</i>
	1315 - 1345 (30min)	Seagrass importance Classroom activity: seagrass importance
	1345 - 1430 (45min)	Seagrass threats* Classroom activity: seagrass threats
	1430 - 1445 (15min)	Seagrass monitoring*
	1445 - 1500 (15min)	<i>Break</i>
	1500 - 1600 (60min)	Seagrass-Watch: how to sample* Classroom activity: estimating percent cover
	1600 - 1645 (45min)	Seagrass-Watch: how data is used*
	1645 - 1700 (15min)	<i>Wrap-up for day</i>

Sunday 10th March 2013 (Keyser Island)

1200 - 1215 (15min)	Safety briefing & risk assessment
1215 - 1415 (2hrs)	Field exercise: Seagrass-Watch monitoring <i>Where:</i> Keyser Island channel <ul style="list-style-type: none"> • <i>meet at Nancy Cato park</i> • <i>be punctual</i> • <i>be well rested</i> <i>What to bring:</i> <ul style="list-style-type: none"> • <i>hat, sunscreen (Slip! Stop! Slap!)</i> • <i>dive booties or old shoes that can get wet</i> • <i>drink/refreshments and energising snack</i> • <i>wet weather gear: poncho/raincoat</i> • <i>insect repellent</i> • <i>polaroid sunglasses (not essential)</i> • <i>simple medical kit in case of injuries to yourself</i> • <i>change of footwear and clothes</i> • <i>enthusiasm</i> <p><i>You will be walking across a seagrass meadow along a creek bank exposed with the tide, through shallow water.</i></p>
1415 - 1430	Wrap up (<i>on foreshore</i>) <ul style="list-style-type: none"> • check gear • feedback

Low tide: 0.4m at 1321pm (1.1m, 1620)

Background

Seagrasses are unique flowering plants that have evolved to live in sea water. Seagrasses belong to a group of plants known as **angiosperms** (flowering plants).

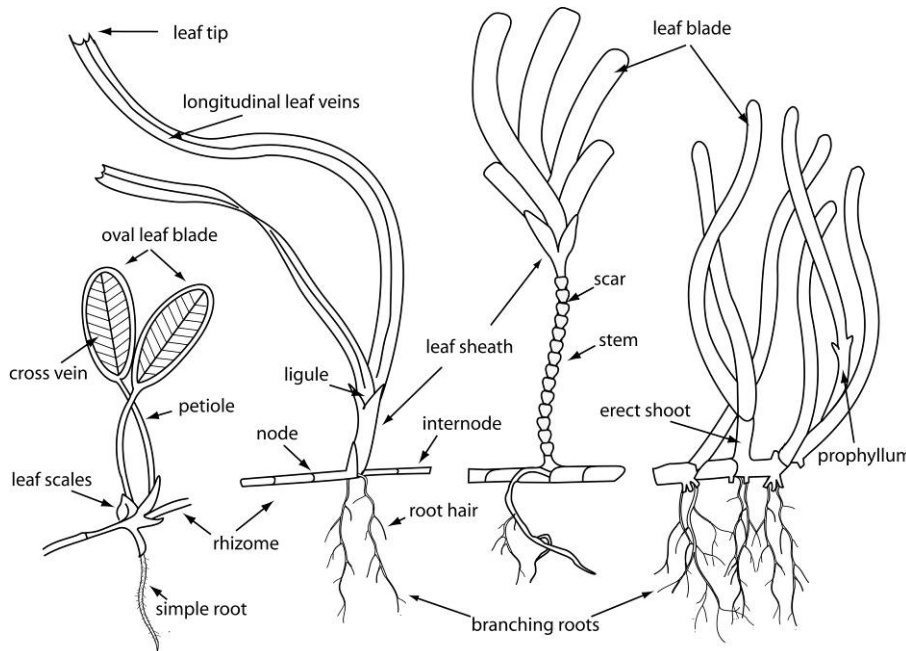

Composite illustration demonstrating morphological features used to distinguish main seagrass taxonomic groups.

Various common names are applied to seagrass species, such as turtle grass, eelgrass, tape grass, spoon grass and shoal grass. These names are not consistently applied among countries. Coastal communities would almost certainly recognise the term “turtle grass” as referring to the shallow subtidal and intertidal seagrasses that turtles are associated with.

Like terrestrial (land living) plants, a seagrass can be divided into its **veins** (lignified conducting tissue that **transports food, nutrients and water around the plant**), stem, roots (buried in the substrate) and reproductive parts such as flowers and fruits. Algae do not have veins in their leaves nor do they possess roots (anchoring to the surface of the substrate by a holdfast) or produce flowers or seeds.

They are called “seagrass” because most have ribbon-like, grassy leaves. There are many different kinds of seagrasses and some do not look like grass at all. Seagrass range from the size of your fingernail to plants with leaves as long as 7 metres. Some of the shapes and sizes of leaves of different species of seagrass include an oval (paddle or clover) shape, a fern shape, a long spaghetti like leaf and a ribbon shape. Species that have a paddle or fern shaped leaf are called *Halophila*. Ones that have a ribbon shaped leaf are the *Cymodocea*, *Thalassia*, *Thalassodendron*, *Halodule* and *Zostera*. Spaghetti-like seagrass is called *Syringodium*. At the base of a leaf is a sheath, which protects young leaves. At the other end of a leaf is the tip, which can be rounded or pointed. The vertical stem, found in some species, is the upright axis of the plant from which leaves arise (attach). The **remnants of leaf attachment** are seen as **scars**.

Seagrass leaves lack stomata (microscopic pores on the under side of leaves) but have thin cuticle to allow gas and nutrient exchange. They also possess

Seagrass are marine flowering plants

Seagrasses have roots, stems and leaves

Seagrass is different to seaweed (algae) as they have internal veins, true roots and produce flowers, fruits and seeds

Leaves of different seagrass species can be shaped like a flattened ribbon, look like a fern, round like a clover, or even spaghetti shaped

large thin-walled aerenchyma. The aerenchyma are commonly referred to as veins as they carry water and nutrients throughout the plant (i.e. an **internal vascular system**). Aerenchyma is specialized tissue having a regular arrangement of air spaces, called lacunae, that both provides buoyancy to the leaves and facilitate gas exchange throughout the plant. Leaves have a very thin cuticle, which allows gas and some nutrient diffusion into them from the surrounding water. Veins can be across the leaf blade or run parallel to the leaf edge. Also within the leaves are chloroplasts, which use the sun's light to convert carbon dioxide and water into oxygen and sugar (photosynthesis). The sugar and oxygen are then available for use by other living organisms.

The roots and horizontal stems (**rhizomes**) of seagrass are often buried in sand or mud. They **anchor the plant, store carbohydrates and absorb nutrients**. Roots can be simple or branching and all have fine hairs to help absorb nutrients. Rhizomes are formed in segments with leaves or vertical stems rising from the joints, called **nodes** or scars. Sections between the nodes are called internodes. Seagrasses depend upon the growth of rhizomes to increase the area they occupy. This vegetative growth is the most common mode of growth for seagrasses. Although the rhizome mainly runs horizontally, some lateral branches are more or less erect and bear leaves (erect shoots). Sometimes the leaves are on a special type of stalk, called a petiole.

The Roots and Rhizomes of seagrasses are well endowed with aerenchyma and the lacunae are extensive and continuous with leaf tissues. **Oxygen** transport to the roots creates an oxic environment around the roots, facilitating nutrient uptake.

Seagrasses have flowers and pollination systems that are well adapted for pollination by water. **Seagrass form tiny flowers, fruits and seeds**. Most seagrasses have separate male and female plants. In most species, flowers are small, white and are borne at the base of the leaf clusters. The stamens (male parts) and pistils (female parts) extend above the petals to facilitate pollen release and pollination respectively.

Most seagrasses reproduce by pollination while submerged and complete their entire life cycle underwater. Pollination in seagrasses is hydrophilic (aided by water), and can occur by: (i) pollen transported above water surface (e.g., *Enhalus*); (ii) pollen transported on water surface (e.g., *Halodule*), or; (iii) pollen transported beneath water surface (e.g., *Thalassia*).

Seagrass pollen grains are elongated into a filamentous shape. The filamentous nature of pollen grains facilitates transport within the water medium, **mainly by water currents**. *Halophila* and *Thalassia* have spherical pollen grains, but they remain joined together in long chains, giving the same effect as having elongated, filamentous pollen grains.

After fertilization, the ovary of the female flower develops into a fruit. In seagrasses, fruit development and fruit structure are as diversified as their flowering patterns and floral structures. In general the seeds, ranging in the size from 0.3 to 0.5mm in some *Halophila* species to more than 1–2 cm in *Enhalus*, are furnished with a nutrition reserve and sink rather than float. The **number of seeds within a fruit also varies from 1 (e.g. *Halodule uninervis*) up to 25 (e.g. *Halophila ovalis*).**

Seagrass have veins and air channels in their leaves and stems so they can carry water, food and absorb gases

Seagrasses rely on light to convert carbon dioxide and water into oxygen and sugar (photosynthesis)

Roots can be simple or branching and all have fine hairs to help absorb nutrients

Seagrass pump oxygen into the sediment via their roots

Seagrass have flowers, fruits and seeds

Pollination occurs in the water

Pollen from male seagrass flowers is mainly dispersed to female seagrass flowers by tidal currents

Seagrasses are not true grasses

Seagrasses are more closely related to lilies

Seagrass taxonomy

Seagrasses are monocotyledons that are not true grasses (true grasses belong to the family Poaceae), but are rather more closely related to the lily family.

Seagrasses evolved approximately 100 million years ago from land plants that returned to the sea in a least three separate lineages or families. Thus, seagrasses are not a taxonomically unified group but a 'biological' or 'ecological' group. The evolutionary adaptations required for survival in the marine environment have led to convergence (similarity) in morphology.

Worldwide, there are about 12 major divisions, consisting of approximately 60 species (up to 72) of seagrass. The highest concentration of species occurs in the Indo-West Pacific region.

Over 30 species can be found within Australian waters. The most diverse seagrass communities are in the waters of north-eastern Queensland and southern Western Australia.

Various common names are applied to seagrass species, such as turtle grass, eelgrass, tape grass, spoon grass and shoal grass. Seagrasses are not seaweeds. Seaweed is the common name for algae.

Seagrass requirements for growth

Seagrasses require light, nutrients, carbon dioxide, substrate for anchoring, tolerable salinity, temperature and pH to survive. The requirements for a seagrass to be able to exist in the marine environment include:

1. adaptation to life in saline (salty) medium
2. growth when completely submerged
3. anchoring system able to withstand the forces of wave action and tidal currents
4. hydrophilous pollination (pollination aided by water).

The need for physiological adaptations to life in sea water is obvious when one considers that seagrasses evolved from land plants, and most land plants are unable to tolerate even small quantities of salt. In contrast to land plants, some seagrasses can tolerate a salinity range from 4 to 65 parts per thousand (2x seawater concentration). Typically, seagrasses grow best in salinities of 35 parts per thousand. Not all species tolerate all salinities equally well, and salinity tolerance may be a factor promoting different species distributions along salinity gradients, e.g., going up estuaries. Some seagrasses can survive in a range of conditions encompassing fresh water, estuarine, marine, or hypersaline (very salty). A limiting factor for many intertidal seagrasses is osmotic impacts resulting from hypersalinity due to evaporation

Seagrasses being plants need light for photosynthesis. Light availability is the most dominant overriding factor in seagrass growth. Seagrasses have high minimum light requirements (e.g. 10-20% on average, 4.4% minimum and 29% maximum depending on species) of surface irradiance) because: (i) they have a high respiratory demand to support a large non-photosynthetic biomass (e.g. roots, rhizomes); (ii) they lack certain pigments and therefore can utilise only a restricted spectral range; and (iii) they must regularly oxygenate their root zone to compensate for anoxic sediment. However, light in the intertidal can be in excess of requirements and excess light can cause

Seagrass evolved 100 million years ago from land plants that returned to the sea

There are around 60 species of seagrass found in ocean throughout the world

Seagrasses need plenty of sun and clean water to grow.

Seagrasses are physiologically adapted to life in sea water

Seagrasses can tolerate a range of salinities. Some species are less tolerant than others

Light availability is the most important factor determining seagrass growth

Seagrasses require between 10-20% of surface light to grow

temporary photo damage. UV exposure can also have significant impacts on seagrasses.

Temperature influences the rate of growth and the health of plants, particularly at the extremes. As water temperatures increase (up to 38°C) the rate of photorespiration increases reducing the efficiency of photosynthesis at a given CO₂ concentration. The cause of thermal stress at higher temperatures (38°C to 42°C) is the disruption of electron transport activity via inactivation of the oxygen producing enzymes (proteins) of photosystem II. Above these temperatures many proteins are simply destroyed in most plants, resulting in plant death.

Temperature also controls the range of pH and dissolved carbon dioxide (CO₂) concentrations in the water column; factors critical in plant survival in the marine environment.

Seagrasses require inorganic carbon for growth. They uptake inorganic carbon at the leaf surface via two pathways which are species-specific. Some species use bicarbonate (HCO₃⁻) as an inorganic carbon source (e.g. *Halophila ovalis*, *Cymodocea rotundata*, *Syringodium isoetifolium* and *Thalassia*), whereas others use enzymes to make CO₂ available as the inorganic carbon source (e.g. *Enhalus acoroides*, *Halodule*, *Cymodocea serrulata*).

Seagrasses require two key nutrients, nitrogen and phosphorous, for growth. In the coastal regions, seagrasses appear to be primarily limited by nitrogen and secondarily by phosphorus. The demand for nutrients by seagrasses appears to be seasonally dependent. During the growing season the demand for nutrients is high, however during the senescent season elevated nutrients may become toxic.

The availability of nutrients to seagrasses may also be dependent on sediment quality / geochemistry. Bioavailability of nutrients is dependent on particle size and type. For example, clay content influences sediment adsorptive capacity — the more clays the greater the absorptive capacity — and, calcium carbonate binds phosphorus, limiting its bioavailability.

Sediment quality, depth and mobility are important factors for seagrass composition, growth and persistence. Most seagrasses live in sand or mud substrates where their roots and rhizomes anchor the plants to the see floor. Some seagrasses such as *Cymodocea* spp. prefer deeper sediments while others can tolerate a broad range of sediment depths. Colonising seagrasses such as *Halophila* spp. and *Halodule uninervis* are better suited to mobile sediments than larger species. The biogeochemical characteristics of sediment that can affect the nutrient content/binding capacity, organic content and oxygen levels. Seagrasses are unable to grow in sediments of high organic content.

Currents and hydrodynamic processes affect almost all biological, geological and chemical processes in seagrass ecosystems at scales from the smallest (physiological and molecular) to the largest (meadow wide). The pollination of seagrass flowers depends on currents and without current flows, vegetative material and seeds will not be transported to new areas, and species will not be exchanged between meadows. Factors such as the photosynthetic rate of seagrasses depend on the thickness of the diffusive boundary layer that is determined by current flow, as is the sedimentation rate. Both influence growth rates of seagrass, survival of seagrass species and overall meadow morphology.

Water temperature influences the rate of growth and the health of seagrass

Seawater temperatures above 40°C will stress seagrass. Death occurs at temperatures above 43°C

Seagrass require inorganic carbon for growth

Seagrass uptake carbon via two different pathways

Seagrass require two key nutrients, nitrogen and phosphorous, for growth

Nutrient availability to seagrass is dependent on the type of sediment they grow in

Most seagrass live in sand or mud sediments

Sediment movement can determine the presence of seagrass species

Tidal currents are important for pollination and exchange of gases from the water to the plant

Where are seagrasses found?

Seagrasses are found in ocean throughout the world. They occur in tropical (hot), temperate (cool) and the edge of the arctic (freezing) regions. Seagrass are mainly found in bays, estuaries and coastal waters from the mid-intertidal (shallow) region down to depths of 50 or 60 metres. Most species are found in clear shallow inshore areas **between mean sea-level and 25 metres depth**.

Seagrasses survive in the intertidal zone especially in locations sheltered from wave action or where there is pooling of water at low tide, (e.g., reef platforms and tide pools), which protects seagrass from elevated temperatures and drying.

Seagrasses inhabit all types of ground (substrates), from mud to rock. The most extensive seagrass meadows occur on soft substrates like sand and mud.

The depth range of seagrass is most likely to be controlled at its deepest edge by the availability of light for photosynthesis. Exposure at low tide, wave action and associated turbidity and low salinity from fresh water inflow determines seagrass species survival at the shallow edge.

Seagrass plants form small patches that develop into large continuous meadows. These meadows may consist of one or many species: sometimes up to 12 species present within one location.

How are seagrasses important to the marine ecosystem?

Seagrass communities are one of the most productive and dynamic ecosystems globally. Seagrasses may significantly influence the physical, chemical and biological environments in which they grow by acting as ‘ecological engineers’. They provide habitats and nursery grounds for many marine animals and act as substrate stabilisers.

Seagrass meadows are highly productive. They have been documented to create habitat complexity compared with unvegetated areas, providing up to 27 times more habitable substrate, as well as providing refuge and food for a range of animals. About 40 times more animals occur in seagrass meadows than on bare sand.

One of the most important roles of seagrasses is providing a nursery and shelter area for fish and prawns which are valuable to fisheries. Juveniles of some important species which depend on seagrass meadows include fish such as perch, mullet, whiting, tailor, bream, snappers, emperors and sweetlips. Commercial penaeid prawns such as red spot king, brown tiger, grooved tiger and endeavour also live in seagrass meadows as juveniles. Tropical rock lobsters also live in seagrass meadows as juveniles. Shellfish such as some oysters and pearl shell may be more likely to settle and survive where there is seagrass. Juvenile and adult sandcrabs and flathead are just two species which spend most of their lives in seagrass meadows, where there is not only food but also protection from strong tidal currents and predators. Larger predatory animals such as herons, cormorants, sharks, barramundi, salmon, crocodiles, etc, are also attracted to the seagrass meadows by the schools of forage fish which seek shelter there.

Seagrass meadows are a major food source for a number of grazing animals and are considered very productive pastures of the sea. The dugong

Seagrass are commonly found in estuaries, shallow coastal locations, and on reef-tops.

Seagrass are mainly found in clear shallow inshore areas between mean sea-level and 25 metres depth.

The depth that seagrass are found underwater depends on the light availability (water clarity)

Seagrass plants form small patches that develop into large meadows

Seagrasses are important habitat and feeding grounds for marine organisms.

About 40 times more animals occur in seagrass meadows than on bare sand.

Seagrasses are important nursery grounds for fish, and they support many human commercial activities.

(*Dugong dugon*) and the green turtle (*Chelonia mydas*) mainly feed on seagrass. An adult green turtle eats about **two kilograms** of seagrass a day while an adult dugong eats about 28 to 40 kilograms a day. Although dugongs and turtles will feed on any seagrass species within their range, if a range of species is available, they select seagrass species for food which are high nitrogen, high starch and low fibre. For example, the order of seagrass species preference for dugongs is *Halophila ovalis* > *Halodule uninervis* > *Zostera capricorni*. In sub-tropical and temperate areas, water birds such as black swans also eat seagrass.

Decomposing seagrasses provide food for benthic (bottom-dwelling) aquatic life. The decaying leaves are broken down by fungi and bacteria which in turn provide food for other microorganisms such as flagellates and plankton. Microorganisms provide food for the juveniles of many species of marine animals such as fish, crabs, prawns and molluscs.

The rhizomes and roots of the grasses bind sediments on the substrate, where nutrients are recycled by microorganisms back into the marine ecosystem. The leaves of the grasses slow water flow, allowing suspended material to settle on the bottom. This increases the amount of light reaching the seagrass meadow and creates a calm habitat for many species.

Seagrasses are nutrient sinks, buffering or filtering nutrient and chemical inputs to the marine environment. Seagrasses uptake nitrogen and phosphorus from coastal run-off that, in overabundance, can lead to algal blooms that can impair water quality.

Interactions with mangroves and coral reefs

Tropical seagrasses are important in their interactions with mangroves and coral reefs. All these systems exert a stabilizing effect on the environment, resulting in important physical and biological support for the other communities).

Barrier reefs protect coastlines, and the lagoon formed between the reef and the mainland is protected from waves, allowing mangrove and seagrass communities to develop. Seagrasses trap sediment and slow water movement, causing suspended sediment to fall out. This trapping of sediment benefits coral by reducing sediment loads in the water.

Mangroves trap sediment from the land, reducing the chance of seagrasses and corals being smothered. Sediment banks accumulated by seagrasses may eventually form substrate that can be colonized by mangroves. All three communities trap and hold nutrients from being dispersed and lost into the surrounding oceanic waters.

Valuation of seagrasses

The valuation of ecosystem services is a very controversial topic in today's literature. Ecosystem Services are the processes by which the environment produces resources that we often take for granted. For seagrasses it is services such as clean water, preventing erosion, and habitat for fisheries. The economic values of seagrass meadows are very large, although not always easy to quantify. Seagrass meadows are rated the 3rd most valuable ecosystem globally (on a per hectare basis), only preceded by estuaries and wetlands. The average global value of seagrasses for their nutrient cycling services and the raw product they provide has been estimated at 1994 US\$ 19,004 ha⁻¹ yr⁻¹.

Dugongs can eat up to 40kg of seagrass per day.

Dugongs and turtles select seagrass species for food which are high nitrogen, high starch and low fibre

Seagrasses also contribute to the productivity of ecosystems via the detrital food pathway

Seagrass binds sediments and help prevent erosion

Seagrasses slow water flow and increase water clarity

Seagrass help remove harmful nutrient and sediment pollution from coastal waters

Seagrasses, mangroves and coral reef interact, providing physical and biological support for other communities

Seagrass meadows are rated the 3rd most valuable ecosystem globally (more valuable than mangroves or coral reefs)

What causes seagrass areas to change?

Tropical seagrass meadows vary seasonally and between years, and the potential for widespread seagrass loss has been well documented.

Factors which affect the distribution of seagrass meadows are sunlight and nutrient levels, water depth, turbidity, salinity, temperature, current and wave action.

Seagrasses respond to natural variations in light availability, nutrient and trace element (iron) availability, grazing pressure, disease, weather patterns, and episodic floods and cyclones. The dynamic nature of seagrass meadows in response to natural environmental variation complicates the identification of changes caused by humans.

What threatens seagrass?

Seagrass meadows can be easily damaged. Approximately 58% of seagrass meadows globally, have lost part of their distribution. According to reports, the documented losses in seagrass meadows globally since 1980 are equivalent to two football fields per hour.

Some losses are natural due to storms and herbivores, however most losses are the result of human activities. Human pollution has contributed most to seagrass declines around the world.

The most widespread and pervasive cause of seagrass decline is a reduction in available light. Processes that reduce light penetration to seagrasses include pulsed turbidity events during floods, enhanced suspended sediment loads and elevated nutrient concentrations. Poor farming practices can result in excess sediments and fertilizers washing down creeks to the sea. Sewage discharge and stormwater runoff from urban development can elevate nutrients in coastal areas. Boating activity may also stir up sediment, reducing light levels. Phytoplankton and fast-growing macroalgae are also better competitors for light than benthic plants and their biomass can shade seagrasses during progressive eutrophication.

Oil and trace metal contamination can exert direct toxic effects on some seagrass species. Seagrasses are able to bioaccumulate the trace metals and this can have ramifications for grazers such as dugongs.

People can also physically damage or destroy seagrass. Coastal development for boat marinas, shipping ports and housing generally occurs on the coast in areas which are sheltered and seagrass like to grow. Seagrass meadows are either removed or buried by these activities. Coastal developments can also cause changes in water movement. Dredging boat channels to provide access to these developments not only physically removes plants, but can make the water muddy and dump sediment on seagrass. Litter and rubbish can also wash into the sea if not properly disposed. Rubbish can physically and chemically damage seagrass meadows and the animals that live within them.

Boating and fishing activities can physically impact or destroy seagrasses. Boat anchors and their chains can dig into seagrass. Propellers can cut into seagrass meadows and unbalance the rhizome mat. Storms can further exacerbate the damage by the physical force of waves and currents ripping up large sections of the rhizome mat. Uncontrolled digging for bait worm can also physically damage seagrasses and some introduced marine pests and pathogens also have the potential to damage seagrass meadows.

Seagrasses can change due to both natural and human impacts

People can damage or destroy seagrass by pollution (sewage, oil spills and coastal runoff) and physical destruction (dredging, bait & clam digging, boat propellers and anchors/moorings).

Poor farming practices can result in runoff which can damage seagrass by elevating nutrients, reducing available light and releasing herbicides.

Coastal development can have a major impact on seagrass meadows

One of the other significant impacts to seagrass is climate change. The major vulnerability of seagrass to climate change is loss of seagrass in the coastal zone, particularly near river mouths and in shallow areas. The greatest impact is expected to result from elevated temperatures, particularly in shallower habitats where seagrasses grow (e.g., effecting distribution and reproduction). In addition, reduced light penetration from sediment deposition and resuspension are expected due to more intensive cyclones/hurricanes and elevated flooding frequency and amplitude. This will result in even greater seagrass losses, and changes in species composition are expected to occur particularly in relation to disturbance and recolonisation. Following such events, a shift to more ephemeral species and those with lower minimum light requirements is expected.

Climate change can threaten intertidal seagrass by increased seawater temperature and greater physical disturbance from storms

Please note: citations have been removed for ease of reading. Please see *References & Further Reading* for source/citations on scientific facts.

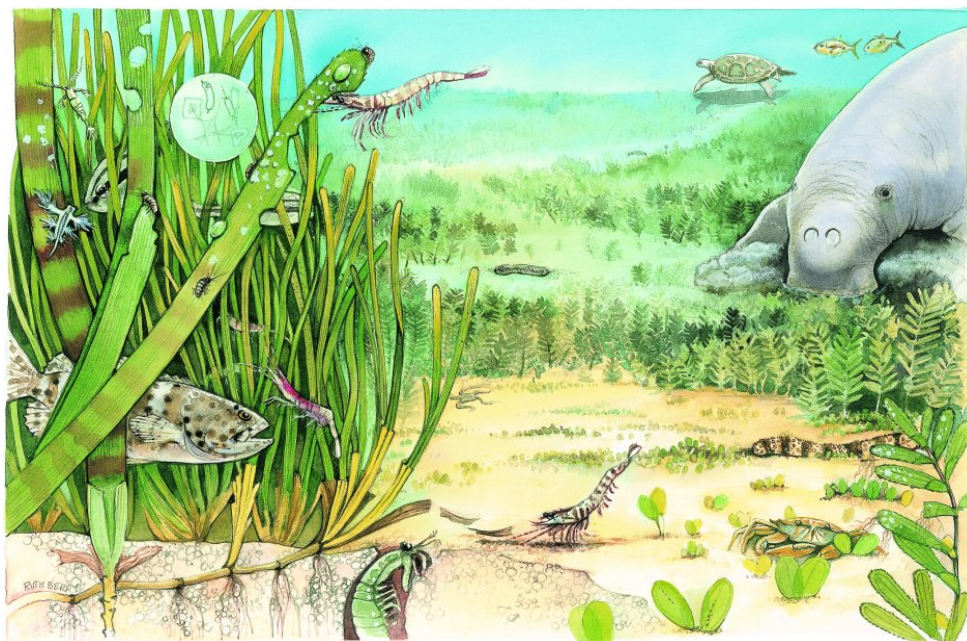

Notes:

.....

.....

.....

.....

.....

.....

.....

Interesting facts:

Over a billion people live within 50 km of a seagrass meadow. Millions of people obtain their protein from animals that live in seagrasses.

The estimated global coverage of seagrass is between 300,000 and 600,000 square kilometres.

A hectare of seagrass absorbs 1.2 kilograms of nutrients per year, equivalent to the treated effluent from 200 people.

In northern Australia, whole seagrass meadows are able to completely replace their leaves (turnover) in around 14 days during the growing season.

A hectare of seagrass sequesters 830 kilograms of carbon per year, equivalent to the CO₂ emissions from an automobile travelling 3,350 km.

One square metre of seagrass can produce up to 10 litres of oxygen per day

In northern Australia, the primary productivity of seagrass meadows is higher than a mangrove forest, a terrestrial forest or grassland.

Seagrasses occupy only 0.1% of the seafloor, yet are responsible for 12% of the organic carbon buried in the ocean, which helps reduce greenhouse gases.

The only endangered marine plant is a species of seagrass (*Halophila johnsonii* in Florida).

There is a single clone of seagrass that is over 6,000 years old (*Posidonia oceanica* in the Mediterranean Sea). It is possibly the world's oldest plant!

The deepest growing seagrass (*Halophila decipiens*), 86 metres, was reported from Cargados Carajos Shoals in the Indian Ocean northeast of Mauritius.

Seagrass produce the longest pollen grains on the planet.

Some intertidal species of seagrasses can lose up to 50% per cent of their water content and still survive.

Did you know that Australia has the highest number of seagrass species of any continent in the world?

In Alaska, seagrasses remain frozen and in a dormant state over winter and do not start to grow again until the thaw.

The longest known seagrass 7.3 metres in length has been reported from Funakoshi Bay, Japan.

40,000 seeds of *Halodule uninervis* have been found in 1 square metre of mudflat.

In Florida, 80% of the above ground seagrass biomass is consumed by parrot fish.

The anchor and chain from one cruise boat can destroy an area of seagrass the size of a football field!

Notes:

.....

.....

.....

.....

.....

.....

.....

.....

.....

.....

.....

.....

.....

.....

.....

.....

.....

.....

.....

.....

.....

.....

.....

.....

Seagrass in the Noosa region of South East Queensland

The South East Queensland (SEQ) region extends from Noosa in the north to Coolangatta in the south. SEQ is one of Queensland's most important natural, recreational, cultural and economic resources.

Seagrasses are a major component of the SEQ marine ecosystems and their contribution to the total primary carbon production (estimated at 105 tonnes of carbon per day (QLD Museum 1998)) is critical to regionally important dugong (Marsh and Lawler 2001) and turtle populations, and productive fisheries (Coles *et al.* 2003). Coastal meadows are important nursery habitat to juvenile fish and prawns (Williams 1997; Coles *et al.* 1993; Blaber 1980; Beumer *et al.* 1997; Zeller 1998; Masel & Smallwood 2000). The seagrass also provide habitat for migratory wading birds and food for black swans. Extensive seagrass meadows occur both on intertidal mudflats and subtidal areas.

Eight seagrass species occur in the SEQ region (*Cymodocea serrulata*, *Halophila decipiens*, *Halophila minor*, *Halophila ovalis*, *Halophila spinulosa*, *Halodule uninervis*, *Syringodium isoetifolium* and *Zostera muelleri* subsp. *capricorni* (aka *Zostera capricorni*)), with *Zostera capricorni* and *Halophila ovalis* the most common, and *Halophila minor* the rarest (Phillips *et al.* 2008); although *H. minor* taxonomy remains under review (see Waycott *et al.* 2004). Seagrass communities in SEQ have been mapped several times over the past 35 years to varying degrees and accuracies.

Seagrass distribution throughout the region is most likely influenced by shelter, sediment characteristics, water turbidity and tidal exposure. The most extensive seagrass meadows in the SEQ region occur in the intertidal zone. Large seagrass meadows occur in areas of wide intertidal flats while small but dense seagrass meadows are found in association with narrow or confined channels. Seagrass do not occur on exposed oceanic shores in the region, but do occur in small intertidal areas within some rivers and creeks flowing directly into the ocean.

Between August 1987 and December 1987 a detailed survey documented the broad extent of seagrass distribution in SEQ (Hyland *et al.* 1989). Hyland *et al.* (1989) identified seven species of seagrass, and estimated approximately 14,170 ha of seagrass meadows (light to dense) and 12,500 ha of sparse or patchy seagrass areas between Coolangatta and Noosa.

In August 1987, approximately 48 ha of seagrass meadows were mapped in estuaries of the Sunshine Coast (Hyland *et al.* 1989). The maps from the surveys estimate 1188 ±409 hectares of seagrass meadows between Noosa and Caloundra (Hyland *et al.* 1989), however, this figure is an over estimate, as the isolated patches within Lakes Cooroibah, Doonella and Weyba were represented in the seagrass distribution maps as large contiguous areas because mapping individual patches was not possible. Only two seagrass species have been reported from the Noosa region: *Zostera muelleri* subsp. *capricorni* and *Halophila ovalis*. The only mapping of seagrass in the Noosa River region since 1987, was in 2007 via remote sensing for an undergraduate project (King 2008), however no estimate of area is available.

SEAGRASS-WATCH IN THE NOOSA REGION

To provide an early warning of change, long-term monitoring has been established on the Noosa River as part of the Seagrass-Watch, global seagrass assessment and monitoring program (www.seagrasswatch.org; McKenzie *et al.* 2000). Establishing a network of monitoring sites on the Noosa region provides valuable information on temporal trends in the

health status of seagrass meadows in the region and provides a tool for decision-makers in adopting protective measures. It encourages local communities to become involved in seagrass management and protection. Working with both scientists and local stakeholders, this approach is designed to draw attention to the many local anthropogenic impacts on seagrass meadows which degrade coastal ecosystems and decrease their yield of natural resources.



Seagrass-Watch monitoring at Noosa:

left - Keyser channel, Feb 2013 (photo courtesy Maree Cliff) and right – Weyba Creek, 2006 (photo courtesy Kris Boody)

Monitoring sites are located at Makepeace Island; Goat Island; Lake Doonella; Keyser Island; and Weyba Creek. Sites were selected based on seagrass density and distribution in the Noosa River, as observed by aerial photography. Areas with low, medium and high impact from recreational and other anthropogenic influences were considered during selection of the monitoring sites.

For more information, visit www.seagrasswatch.org

A guide to the identification of South East Queensland's Seagrasses

Adapted from Waycott, M, McMahon, K, Mellors, J., Calladine, A., and Kleine, D (2004) A guide to tropical seagrasses in the Indo-West Pacific. (James Cook University Townsville) 72pp.

Leaves cylindrical



cylindrical

Syringodium isoetifolium

- leaves taper to a point
- leaves contain air cavities
- inflorescence a "cyme"
- leaves 7-30cm long

Leaves oval to oblong



oval to oblong

obvious vertical stem with more than 2 leaves

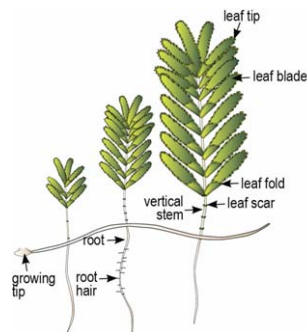

Halophila spinulosa

- leaves arranged opposite in pairs
- leaf margin serrated
- shoots can be up to 15cm long
- 10-20 pairs of leaves per shoot
- leaf 15-20mm long and 3-5mm wide

leaves with petioles, in pairs

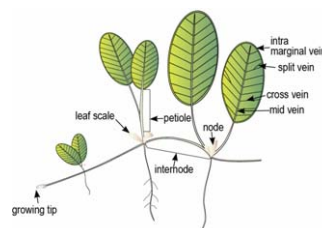

Halophila ovalis

- cross veins 8 or more pairs
- leaf margins smooth
- no leaf hairs
- leaf 5-20mm long
- separate male & female plants

Halophila decipiens

- leaf margins serrated
- 6-8 cross vein pairs
- fine hairs on both sides of leaf blade
- leaves are usually longer than wide

Halophila minor

- oval leaf less than 5mm wide
- less than 8 pairs of cross veins
- leaf margins smooth
- no leaf hairs
- separate male & female plants

Leaves strap-like

Leaves can arise from vertical stem



straplike

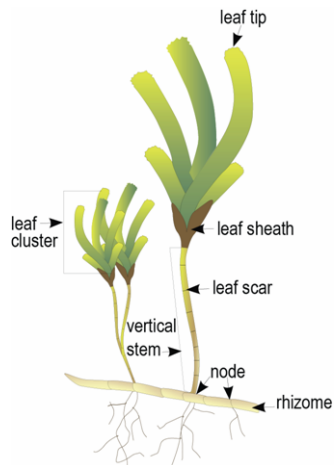

Cymodocea serrulata

- leaf tip rounded with serrated edge
- leaf sheath broadly flat and triangular, not fibrous
- leaf sheath scars not continuous around upright stem

Halodule uninervis

- leaf tip tri-dentate or pointed, not rounded
- leaf with 3 distinct parallel-veins, sheaths fibrous
- narrow leaf blades 0.25-5mm wide
- rhizome usually pale ivory, with small black fibres at the nodes

Leaves always arise directly from rhizome

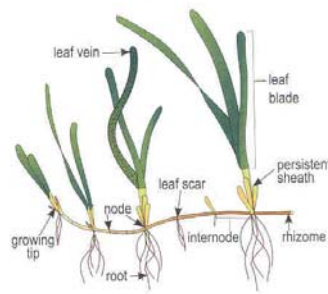



Zostera muelleri subsp. *capricorni*

- leaf with 3-5 parallel-veins
- cross-veins form boxes
- leaf tip smooth and rounded, may be dark point at tip
- rhizome usually brown or yellow in younger parts
- prophyllum present, i.e. a single leaf originating from the rhizome instead of from the vertical, leaf bearing shoot.

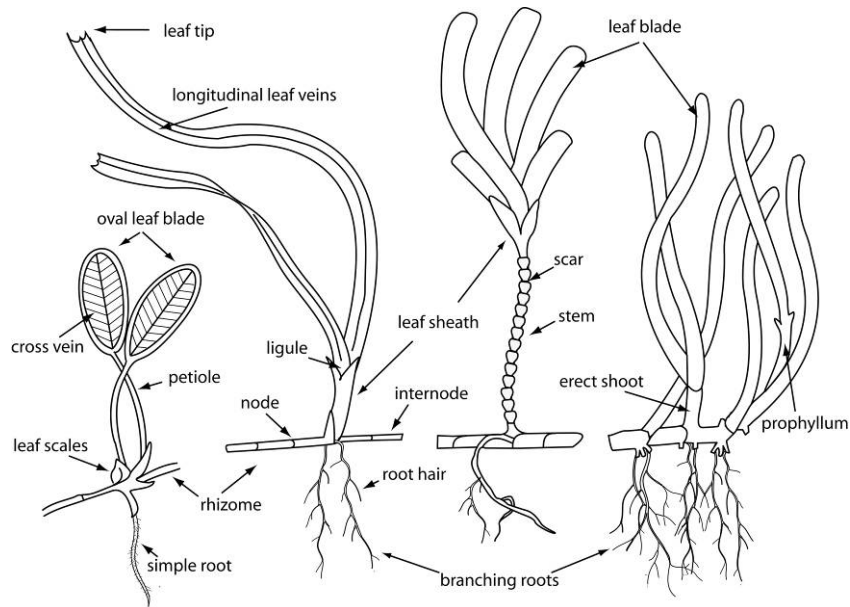
Parts of a seagrass plant

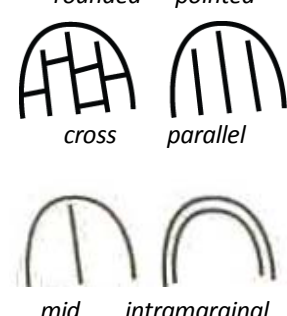

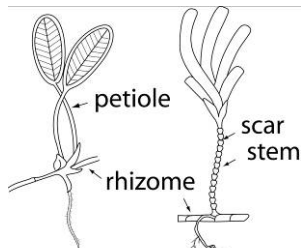
Leaf		
Tip	Can be rounded or pointed. Tips are easily damaged or cropped, so young leaves are best to observe.	 <p style="text-align: center;"><i>rounded</i> <i>pointed</i></p>
Veins	Used by the plant to transport water, nutrients and photosynthetic products. The pattern, direction and placement of veins in the leaf blade are used for identification. <ul style="list-style-type: none"> • cross-vein: perpendicular to the length of the leaf • parallel-vein: along the length of the leaf • mid-vein: prominent central vein • Intramarginal-vein: around inside edge of leaf 	 <p style="text-align: center;"><i>cross</i> <i>parallel</i></p> <p style="text-align: center;"><i>mid</i> <i>intramarginal</i></p>
Edges	The edges of the leaf can be either serrated, smooth or inrolled	 <p style="text-align: center;"><i>serrated</i> <i>smooth</i> <i>inrolled</i></p>
Sheath	A modification of the leaf base that protects the newly developing tissue. The sheath can entirely circle the vertical stem or rhizome (continuous) or not (non-continuous); fully or partly cover the developing leaves and be flattened or rounded. Once the leaf has died, persistent sheaths may remain as fibres or bristles.	 <p style="text-align: center;"><i>clean & flattened</i> <i>fibrous</i></p>
Attachment	The leaf can attach directly to the rhizome, where the base of the leaf clasps the rhizome, or from a vertical stem or stalk (petiole) e.g. <i>Halophila ovalis</i> .	 <p style="text-align: center;"><i>rhizome</i> <i>scar stem</i></p>

Stem

The vertical stem, found in some species, is the upright axis of the plant from which leaves arise (attach). The remnants of leaf attachment are seen as scars. Scars can be closed (*entirely circle the vertical stem*) or open (*do not entirely circle the vertical stem*).

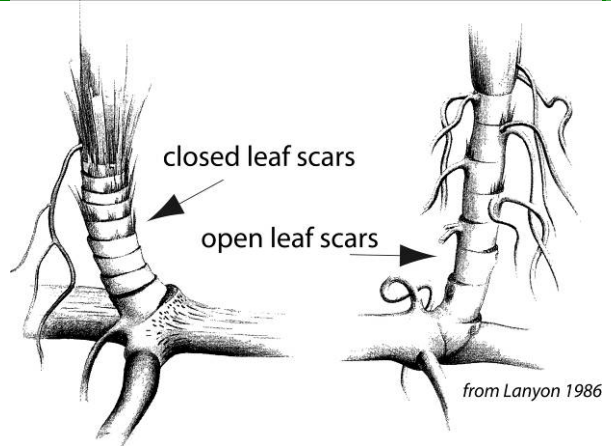

Rhizome

The horizontal axis of the seagrass plant, usually in sediment. It is formed in segments, with leaves or vertical stem arising from the joins of the segments, the nodes. Sections between the nodes are called internodes. Rhizomes can be fragile, thick and starchy or feel almost woody and may have scars where leaves were attached.

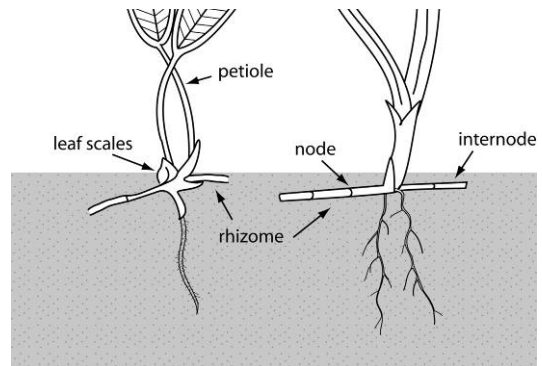

Root

Underground tissues that grow from the node, important for nutrient uptake and stabilisation of plants. The size and thickness of roots and presence of root hairs (very fine projections) are used for identification. Some roots are simple or cordlike, others may be branching, depending on seagrass species.

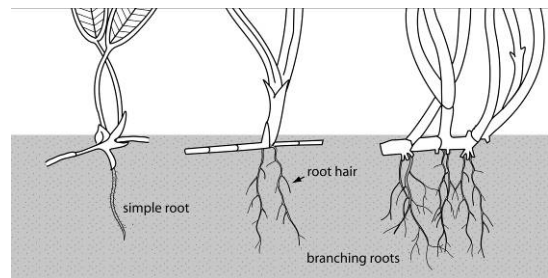

Notes:

.....

.....

.....

.....

.....



Monitoring a seagrass meadow

Monitoring is [the repeated observation of a system, usually to detect change](#). It is an integrated activity to evaluate the condition of the physical, chemical and biological character of the environment. Environment monitoring programs provide coastal managers with information and assist them to make decisions with greater confidence.

Environmental monitoring programs are ideally designed to: quantify the causes of change; examine and assess acceptable ranges of change for the particular site; and to measure levels of impacts.

Common drivers (reasons) for monitoring include: community interest; government policies such as Coastal Strategies and Plans, Oceans Policy, State of the Environment Reporting (SoE), Water Quality guidelines or Best Practice Guidelines; and Government Legislation (e.g., Fish Habitat Protection).

Users of the monitoring program information/results are diverse, including for example: the general public, environmental regulators - legislators, resource managers and scientists.

There are a number of issues to consider when implementing a monitoring program, including: ensure the protocols used have explicit objectives; clearly identified responsibilities of the partners (e.g. Gov agencies, consultants, community groups); a clear and defensible rationale for using the parameters that are measures (e.g. physico/chemico, biological indicators); to have a [baseline \(first\) assessment / measure against which subsequent changes can be measured/compared](#); knowledge of spatial and temporal variation prior to designing the program (i.e. pilot study); clearly defined field protocols; data management procedures, ensure the level of change and accuracy of the detection is appropriate (as will vary according to the methodology); selection of statistical tools; and a mechanism to [reduce and manage errors \(i.e. QA/QC program\)](#).

Appropriate Quality Assurance/Quality Control (QA/QC) procedures are an integral component of all aspects of sample collection and analysis in monitoring programs. This includes participation in relevant inter-laboratory studies, proficiency testing, and the use of standard reference materials. Monitoring programs often include the following guidelines for implementation by data collectors and reporters:

- appropriate methods must be in place to ensure consistency in field procedures to produce robust, repeatable and comparable results including consideration of sampling locations, replication and frequency;
- all methods used must be fit for purpose and suited to a range of conditions;
- appropriate accreditation of participating laboratories or provision of standard laboratory protocols to demonstrate that appropriate laboratory QA/QC procedures are in place for sample handling and analysis;
- participation in inter-laboratory performance testing trials and regular exchange of replicate samples between laboratories;
- rigorous procedures to ensure 'chain of custody' and tracking of samples;
- appropriate standards and procedures for data management and storage; and
- a process to ensure data collectors are aware of any errors and provide an opportunity to clarify or correct data.

Monitoring seagrass

Seagrasses are often at the downstream end of catchments, receiving runoff from a range of agricultural, urban and industrial land-uses. Seagrass communities are generally susceptible to changes in water quality and environmental quality that make them a useful indicator of environmental health. Seagrass make good **bioindicators** of environmental health because they are:

- are widely distributed;
- have an important ecological role;
- are sessile plants which show measurable and timely responses to external stressors/impacts (rather than relocating to a less stressful environment) and;
- are integrative of environmental conditions.

Several factors are important for the persistence of healthy seagrass meadows, these include: sediment quality and depth; water quality (temperature, salinity, clarity); current and hydrodynamic processes; and species interactions (e.g., epiphytes and grazers). Seagrass generally respond in a typical manner that allows them to be measured and monitored. In reporting on the health of seagrasses it is important to consider the type of factors that can effect growth and survival. Factors include:

- increased turbidity reduces light penetration through the water, interfering with photosynthesis and limiting the depth range of seagrass;
- increased nutrient loads encourages algal blooms and epiphytic algae to grow to a point where it smothers or shade seagrasses, thereby reducing photosynthetic capacity;
- increased sedimentation can smother seagrass or interferes with photosynthesis;
- herbicides can kill seagrass and some chemicals (e.g., pesticides) can kill associated macrofauna;
- boating activity (propellers, mooring, anchors) can physically damage seagrass meadows, from shredding leaves to complete removal;
- storms, floods and wave action can rip out patches of seagrasses.

Seagrass-Watch

A simple method for monitoring seagrass resources is used in the Seagrass-Watch program. This method uses standardised measurements taken from sites established within representative intertidal meadows to monitor seagrass condition. The number and position of sites can be used to investigate natural and anthropogenic impacts.

Seagrass-Watch is one of the largest seagrass monitoring programs in the world. Since it's genesis in [March 1998](#) in Australia, Seagrass-Watch has now expanded internationally to more than 26 countries. Monitoring is currently occurring at over 300 sites. To learn more about the program, visit www.seagrasswatch.org.

Seagrass-Watch aims to raise awareness on the condition and trend of nearshore seagrass ecosystems and provide an early warning of major coastal environment changes. Participants of Seagrass-Watch are generally volunteers from a wide variety of backgrounds who all share the common interest in marine conservation. Most participants are associated with established local community groups, schools, universities & research institutions, government (local & state) or non-government organisations.

Seagrass-Watch integrates with existing education, government, non-government and scientific programs to raise community awareness to protect this important marine habitat for the benefit of the community. The program has a strong scientific underpinning with an

emphasis on consistent data collection, recording and reporting. Seagrass-Watch identifies areas important for seagrass species diversity and conservation and the information collected is used to assist the management of coastal environments and to prevent significant areas and species being lost.

Seagrass-Watch methods were developed to be rigorous, yet relatively simple and easy to use. Each of the parameters used have been carefully chosen with a clear and defensible rationale. The protocols used have explicit objectives and the sampling strategy is prepared using baseline and knowledge of spatial and temporal variation. As the collection of data by a diversity of participants necessitates a high level of training to ensure that the data is of a standard that can be used by management agencies. After 6–9 hours of training, participants can produce reliable data. Training includes both formal and informal approaches. Formal training is conducted by Seagrass-Watch HQ for participants 18 years of age and includes formal lectures and on-site assessments with a tiered level of certification for competency. Formally trained participants are certified to supervise on-site monitoring and demonstrate (i.e. informally train) monitoring methods. Informal training is also conducted by local coordinators and/or scientists. Ideally, at least one formally trained volunteer is present at each monitoring event. Evidence of competency is securely filed at Seagrass-Watch HQ.

Seagrass-Watch has an accepted Quality Assurance-Quality Control program in place to ensure that the program is producing data of high quality, and that time and resources are not wasted. Seagrass-Watch HQ has systems in place to manage the way Seagrass-Watch data is collected, organised, documented, evaluated and secured. The Seagrass-Watch program collects and collates all data in a standard format. By using simple and easy methods, Seagrass Watch ensures completeness (the comparison between the amounts of valid or useable data originally planned to collect, versus how much was collected). Standard seagrass cover **calibration sheets** are used to ensure precision (the degree of agreement among repeated measurements of the same characteristic at the same place and the same time) and consistency between observers and across sites at monitoring times to [ensure percentage covers are close to a true or standardised value](#).

Other QAQC procedures include the selection of intertidal seagrass sites which are **permanently marked** with either plastic star pickets or an accurate (± 3 m) GPS waypoint. Labels identifying the sites and contact details for the program are attached to these pickets. Positions of 0 m and 50 m points for all three transects at a site are also noted using GPS. This ensures that the same site is monitored each event and that [data can be compared between periods of time](#).

Ongoing standardisation of observers is achieved by on-site refreshers of standard percentage covers by all observers prior to monitoring and through ad hoc comparisons of data returned from duplicate surveys (e.g. either a site or a transect will be repeated by scientist – preferably the next day and unknown to volunteers). Any discrepancy in these duplicates is used to identify and subsequently mitigate bias. For the most part however uncertainties in percentage cover or species identification are mitigated in the field via direct communication (as at least one experienced/certified observer is always present), or the collection of voucher specimens (to be checked under microscope and pressed in herbarium) and the use of a digital camera to record images (protocol requires at least 27% of quadrats are photographed) for later identification and discussion.

Seagrass-Watch HQ has implemented a quality assurance management system to ensure that data collected is organised and stored and able to be used easily. All data (datasheets and photographs) received are entered onto a relational database on a secure server. Receipt of all original data hardcopies is documented and filed within the James Cook University Management System, a formally organised and secure system. Seagrass-Watch HQ operates as custodian of data collected from other participants and provides an evaluation and analysis of

the data for reporting purposes. Access to the IT system and databases is restricted to only authorised personnel. Provision of data to a third party is only on consent of the data owner/principal.

Seagrass-Watch HQ checks all data for completeness, consistency and accuracy. All data submitted to Seagrass-Watch HQ it is first checked from compliancy:

- *legible original datasheets,*
- *good quality quadrat photographs (high resolution),*
- *voucher specimens (if required) and*
- *completed MS Excel spreadsheet.*

Validation is provided by checking observations against photographic records to ensure consistency of observers and by identification of voucher specimens submitted. In accordance with QA/QC protocols, Seagrass-Watch HQ advises observers via an official **Data Error Notification** of any errors encountered/identified and provides an opportunity for correction/clarification (this may include additional training).

Once Seagrass-Watch HQ has completed all checks, a field in the Master database identifies data as either passed, quarantined, non-compliant or not-passed. Non-compliant data is used for large-scale summary reporting only if the data quality is deemed acceptable, i.e. if it was collected by a Level 1 trained participant, that the scans/copies of datasheets are OK (*only if originals are not available*), and/or that the quadrat images were acceptable to complete QAQC, etc. If data quality is unacceptable, the data is either not entered into the Master database or remains quarantined/not-passed (excluded from analysis & reporting). If predominantly non-compliant data is used for detailed analysis and reporting at a site or location/region, it is marked on the outputs with a notice of non-compliance (e.g., site graphs). If officially requested data is non-compliant, a note in the metadata advises of non-compliance and includes a caveat to "use with caution". Any data considered unsuitable (e.g. nil response to data notification within thirty days) is quarantined or removed from the database.

Seagrass-Watch employs a proactive approach to monitoring, involving ongoing training for participants and the continued development of new methods and refinement of existing methods, including location/habitat specific calibration sheets, operation & validation of autonomous temperature and light loggers, etc. Quality data reassures the data users (e.g., coastal management agencies) that they can use the data to make informed decisions with confidence.

Seagrass-Watch monitoring efforts are vital to assist with tracking global patterns in seagrass health, and assessing human impacts on seagrass meadows, which have the potential to destroy or degrade these coastal ecosystems and decrease their value as a natural resource. Responsive management based on adequate information will help to prevent any further significant areas and species being lost. To protect the valuable seagrass meadows along our coasts, the community, government and researchers have to work together.

THE GOALS OF THE PROGRAM ARE:

- *To educate the wider community on the importance of seagrass resources*
- *To raise awareness of coastal management issues*
- *To build the capacity of local stakeholders in the use of standardised scientific methodologies*
- *To conduct long-term monitoring of seagrass & coastal habitat condition*
- *To provide an early warning system of coastal environment changes for management*
- *To support conservation measures which ensure the long-term resilience of seagrass ecosystems.*

Seagrass-Watch Protocols

Source: McKenzie, L.J., Campbell, S.J. & Roder, C.A. (2001) *Seagrass-Watch: Manual for Mapping & Monitoring Seagrass Resources by Community (citizen) volunteers*. (QFS, NFC, Cairns) 100pp (www.seagrasswatch.org/manuals.html)

Site layout

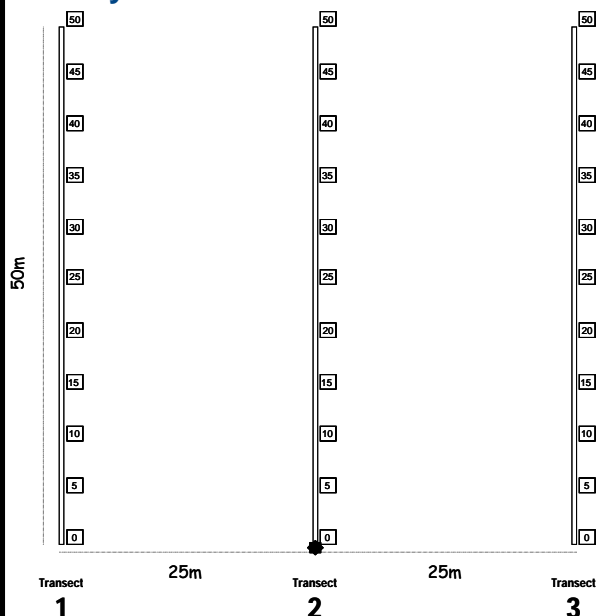

Quadrat code = site + transect+quadrat

e.g., P11225 = Pigeon Is. site 1, transect 2, 25m quadrat

Pre-monitoring preparation

Make a Timetable

Create a timetable of times of departure and arrival back, and what the objective of the day is and what is to be achieved on the day. Give a copy of this to all volunteers involved in advance so they can make their arrangements to get to the site on time. List on this timetable what the volunteers need to bring.

Have a Contact Person

Arrange to have a reliable contact person to raise the alert if you and the team are not back at a specified or reasonable time.

Safety

- Assess the risks before monitoring - check weather, tides, time of day, etc.
- Use your instincts - if you do not feel safe then abandon sampling.
- Do not put yourself or others at risk.
- Wear appropriate clothing and footwear.
- Be sun-smart.
- Adult supervision is required if children are involved
- Be aware of dangerous marine animals.
- Have a first aid kit on site or nearby
- Take a mobile phone or marine radio

Necessary equipment and materials

- 3x 50metre fibreglass measuring tapes
- 6x 50cm plastic tent pegs
- Compass
- 1x standard (50cm x 50cm) quadrat
- Magnifying glass
- 3x Monitoring datasheets
- Clipboard, pencils & 30 cm ruler
- Camera & film
- Quadrat photo labeller
- Percent cover standard sheet
- Seagrass identification sheets

Each sampling event

Within the 50m by 50m site, lay out the three 50 transects parallel to each other, 25m apart and perpendicular to shore (see site layout). Within each of the quadrats placed for sampling, complete the following steps:

Step 1. Take a Photograph of the quadrat

- Photographs are usually taken at the 5m, 25m and 45m quadrats along each transect, or of quadrats of particular interest. First place the photo quadrat labeller beside the quadrat and tape measure with the correct code on it.
- Take the photograph from an angle as **vertical** as possible, which includes the entire quadrat frame, quadrat label and tape measure. Avoid having any shadows or patches of reflection off any water in the field of view. Check the photo taken box on datasheet for quadrat.

Step 2. Describe sediment composition

- Dig your fingers into the top centimetre of the substrate and feel the texture. Describe the sediment by noting the grain size in order of dominance (e.g., Sand, Fine sand, Fine sand/Mud).

Step 3. Describe other features and ID/count of macrofauna

- Note and count (whole numbers - never use < or > symbols) any features which may be of interest (e.g. gastropods, hermit crabs, turtle feeding) within the comments column.

Step 4. Estimate seagrass percent cover

- Looking down on the quadrat from above, estimate the total percentage of the seabed (substrate) within the quadrat covered by seagrass. Estimate the footprint/shadow provided by the seagrass shoots.
- Always use the percent cover photo standards (calibration sheets) as your guide, estimating cover as accurate as possible, e.g. 27%, 61%
- If cover is below 3%, you can count the seagrass shoots and calculate percent cover using the rule of 1 shoot = 0.1%

Step 5. Estimate seagrass species composition

- Identify the species of seagrass within the quadrat and determine the percent contribution of each species (starting with least abundant, total composition must equal 100%)
- Use seagrass species identification keys provided and use more than 1 feature to identify the species

Step 6. Measure seagrass canopy height

- Measure canopy height (in centimetres) of the dominant strap-leaf species, ignoring the tallest 20%.
- Measure from the sediment to the leaf tip of 3 shoots, entering all 3 measures onto datasheet

Step 7. Estimate algae percent cover

- Looking down on the quadrat from above, estimate the total percentage of the seabed (substrate) within the quadrat covered by macroalgae (independent of seagrass cover)
- Macroalgae is not attached to seagrass leaves and may be attached to rocks, shells or may be drift

Step 8. Estimate epiphyte percent cover

- Epiphytes are algae attached to seagrass blades and often give the blade a furry appearance.
- First estimate how much of an average seagrass leaf surface is covered, and then how many of the leaves in the quadrat are covered. For example, if 20% of the blades are each 50% covered by epiphytes, then quadrat epiphyte cover is 10%. Use the epiphyte matrix to assist you.
- Do not include epifauna with epiphytes. Epifauna are sessile animals attached to seagrass blades – record % cover of epifauna in the comments or an unused/blank column – do not add to epiphyte cover.

Step 9. Take a voucher seagrass specimen if required

- Place seagrass samples in a labelled plastic bag with a little seawater and a waterproof label. Select a representative specimen of the species and ensure that you have all the plant parts including the rhizomes and roots. Collect plants with fruits and flowers structures if possible.

Step 10. Move to next quadrat

- Repeat steps 1 to 8 for the remaining 32 quadrats

Step 11. At completion of monitoring

- Check data sheets are filled in fully.
- Remove equipment from site (eg non-permanent pegs)

At completion of monitoring

Step 1. Wash & pack gear

- Rinse all tapes, pegs and quadrats with freshwater and let them dry.
- Review supplies for next quarterly sampling and request new materials
- Store gear for next quarterly sampling

Step 2. Press any voucher seagrass specimens if collected

- The voucher specimen should be pressed as soon as possible after collection. Do not refrigerate longer than 2 days, press the sample as soon as possible.
- Allow to dry in a dry/warm/dark place for a minimum of two weeks. For best results, replace the newspaper after 2-3 days.

Step 3. Submit all data

- Data can be entered into the MS-Excel file downloadable from www.seagrasswatch.org. Email completed files to hq@seagrasswatch.org
- Mail original datasheets, photos and herbarium sheets

Seagrass-Watch HQ
TropWATER (James Cook University)
PO Box 6811
Cairns QLD 4870 AUSTRALIA

SEAGRASS SPECIES CODES

Ho

Halophila ovalis

- 8 or more cross veins
- no hairs on leaf surface
- leaf margins smooth
- leaf 5-20mm long

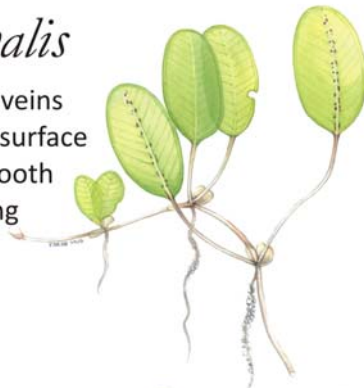

Halophila decipiens

- small oval leaf blade 1-2.5cm long
- 6-8 cross veins
- leaf hairs on both sides
- found at subtidal depths

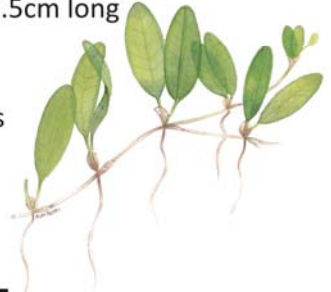

Hd

Hm

Halophila minor

- less than 8 pairs of cross veins
- small oval leaf blade less than 5mm wide
- leaf margins smooth
- no leaf hairs

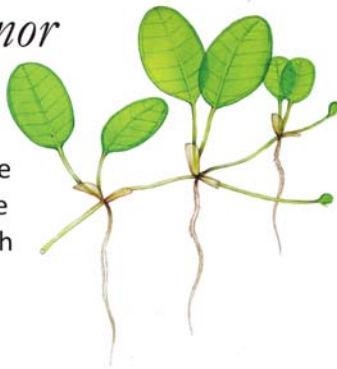

Hu

Halodule uninervis

- flat leaf, 0.25-5mm wide
- trident leaf tip
- 1 central vein
- usually pale rhizome, with clean black leaf scars



Cs

Cymodocea serrulata

- serrated leaf tip
- wide leaf blade (5-9mm wide)
- leaves 6-15cm long
- 13-17 longitudinal veins
- robust/strong rhizome



Hs

Halophila spinulosa

- fern like
- leaves arranged in opposite pairs
- leaves flat & serrated
- erect shoot to 15cm long
- found at subtidal depths



Si

Syringodium isoetifolium

- narrow spaghetti-like leaves
- cylindrical in cross section, 1-2mm diameter
- leaves contain air cavities
- leaf tip tapers to a point
- leaves 7-30cm long
- fleshy white rhizomes



Zc

Zostera muelleri subsp. *capricorni*

- flat leaf, 2-5mm wide
- leaf with 3-5 parallel-veins
- cross-veins form boxes
- leaf tip smooth and rounded, may be dark point at tip
- leaf grows directly from rhizome ie no stem
- rhizome usually brown or yellow in younger parts





SEAGRASS-WATCH MONITORING



ONE OF THESE SHEETS IS TO BE FILLED OUT FOR EACH TRANSECT YOU SURVEY

START of transect (GPS reading)

Latitude: 25° 11.2818' S Longitude: 152° 37.5372' E

OBSERVER: Bev Citizen DATE: 17 / 2 / 09
 LOCATION: Burrum Heads
 SITE code: BH1 TRANSECT no.: 2
 START TIME: 1304 END TIME: 1340

Quadrat (metres from transect origin)	Sediment (eg. mud/sand/shell)	Comments (eg 10x gastropods, 4x crab holes, dugong feeding trails, herbarium specimen taken)	Seagrass coverage (%)	% Seagrass species composition				Canopy height (cm)	% Algae cover	% Epi- cover
				HO	HU	ZC	water			
1 (0m)	Sand	SC x 3 HC x 1	40	30	70		0	514.17	5	33
2 (5m)	S	GAB x 3	33	50	50		0	1017.8	10	18
3 (10m)	mud/sand	worm x 1	18	70	20	10	0	618.5	0	48
4 (15m)	m s	DFT x 1	0				0	0	17	0
5 (20m)	m s shell	HC x 3	36	5	90	5	1cm	917.5	12	57
6 (25m)	m s sh	Turtle cropping	48	100			1cm	NA.	2	96
7 (30m)	Fine Sand		0				1.5cm	0	23	0
8 (35m)	FS	SC x 2 CH x 3	0.7		100		2cm	717.7	18	31
9 (40m)	S m		23	96	4		2cm	214.6	6	17
10 (45m)	m	Mudworek x 2 HC x 1	41	2	95	3	2cm	551.6	3	21
11 (50m)	m s		16	3	7	90	2cm	716.7	38	6

END of transect (GPS reading)

Latitude: 25° 11.2656' S Longitude: 152° 37.5546' E

SC = Sea Cucumbers
 GAB = Gastropod
 DFT = Dugong feeding trail
 HC = Hermit Crab
 CH = Crab Hole

How to use a compass

Modified from Kjetil Kjernsmo <http://www.learn-orienteeing.org/old/lesson1.html>

The most important thing you first need to learn before using a compass are the directions **North, South, East and West**. Look at the figure below and learn how they are. **North** is the most important. *Remember the sun rises in the east and sets in the west.*

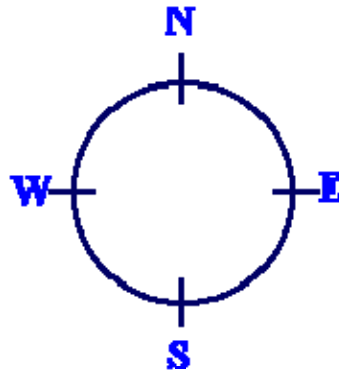

A type of compass often used in Seagrass-Watch is an orienteering compass. It has a large rectangular base-plate (often of clear rigid plastic), on which is a large red travel arrow. Attached to the base-plate is a turnable dial.

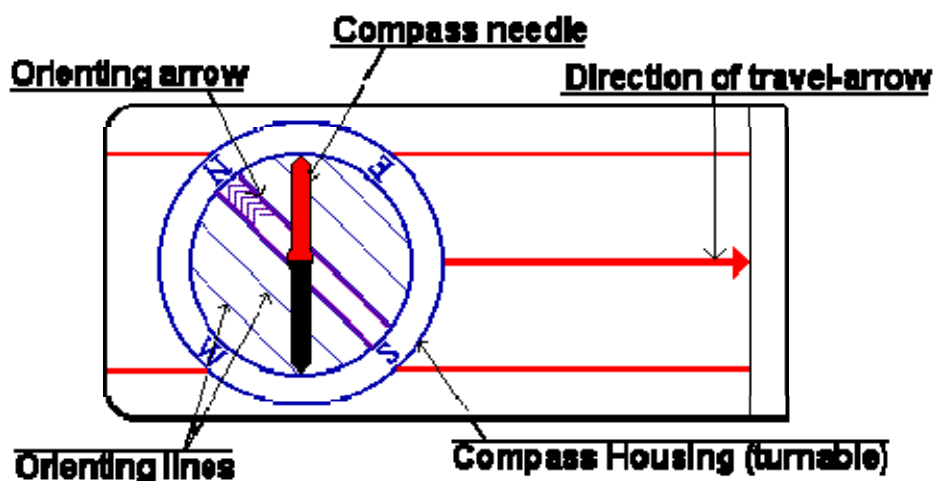

The turnable dial on the compass is called the *Compass housing*. On the edge of the compass housing is a scale from 0 to 360. These are the degrees or the *azimuth*. Also on the housing are the letters N, S, W and E for North, South, West and East.

Within the compass housing is a red and black arrow, called the *compass needle* (on some compasses it might be red and white). **The red part of the needle always points towards the earth's magnetic north pole.**

To find a direction using the compass, you first turn the compass housing until the direction you desire comes exactly in line with the travel arrow, then holding the compass flat, you then turn the whole compass until the compass needle is aligned within the orienting arrow and the red end of the needle points to **N** (north).

For example, if you have arrived at your site and want to lay out transect 2 at bearing (compass heading) of 320 degrees, you first turn the compass housing so that 320 on the housing comes exactly in line with where the large *direction of travel*-arrow meets the housing.

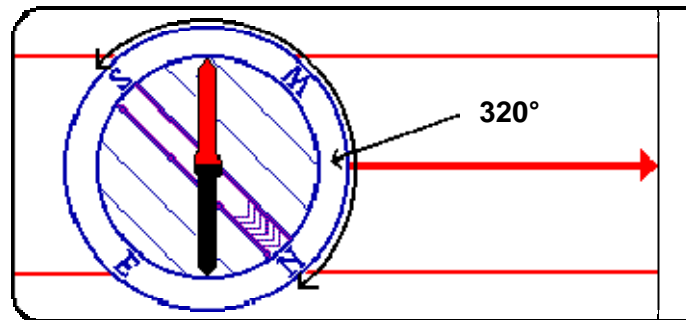

Hold the compass flat in your hand so that the compass needle can turn freely. Then turn yourself, your hand, the entire compass (*make sure the compass housing doesn't turn*), until the compass needle is aligned with the orienting arrow lines inside the compass housing.

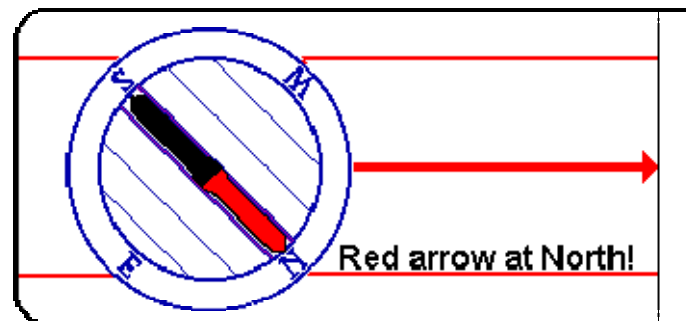

It is *extremely* important that the red (**N**orth) part of the compass needle points to **N**orth in the compass housing. If the red points to the **S**outh, you would walk off in the exact opposite direction of what you want!

A problem can occur if there is a local magnetic attraction. For example, if you are carrying something of iron, it might disturb the arrow. Even a staple in your book might be a problem. Make sure there is nothing of the sort around. There is a possibility for magnetic attractions in the soil as well, "magnetic deviation", but they are rarely seen.

If the needle is directly aligned, you should now be facing 320 degrees. When you are sure you've got it right, fix your eye on some special feature on the horizon (e.g., a rock or coral) with the travel arrow and now head for it. If you are directing someone, keep them informed and line them up with hand signals when they reach the 50m mark.

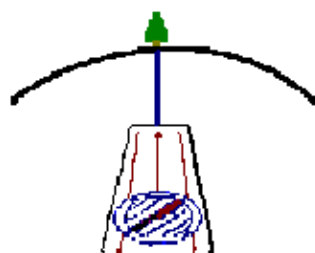

When standing at the start of transect 2 and you want to find the start of transect 1, you need to change your compass bearing by subtracting 90 from the transect bearing (e.g., in the previous example, $320-90= 230$). Measure 25m from the start of transect 2, heading 230 degrees, and put in the peg. This is the start of transect 1. Lay out transect 1 using the same procedure as you just completed for transect 2 (heading 320).

To locate the start of transect 3, you need to change your compass bearing by adding 90 from the transect bearing (e.g., in the previous example, $320+90 = 410$, but as only 360 in a compass your bearing will be 50). Measure 25m from the start of transect 2, heading 50 degrees, and put in the peg. This is the start of transect 3. Lay out transect 3 using the same procedure as you just completed for both transects 1 and 2 (heading 320).

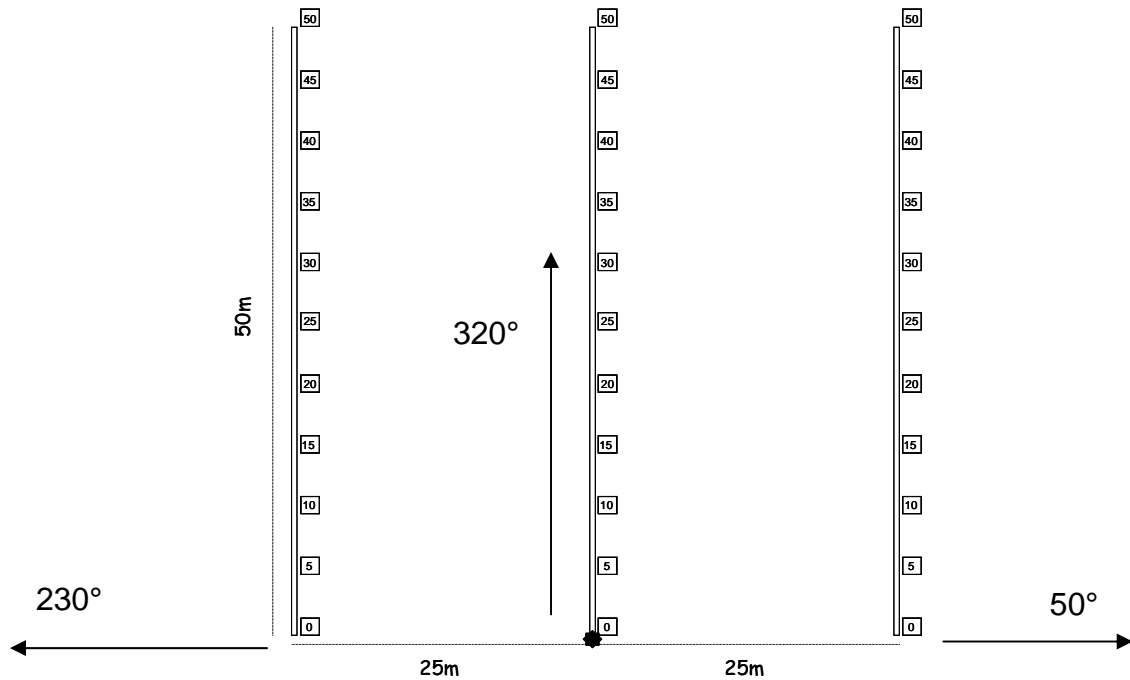

Making a herbarium press specimen

Herbaria are repositories of preserved and labelled plant specimens, arranged to allow easy access and archival storage. The specimens are typically in the form of herbarium sheets: pressed and dried plants that have been attached to a sheet of heavy paper together with a data label. A herbarium specimen is simple in form and low-tech in preparation, yet it preserves a wealth of valuable information. If properly stored, a herbarium specimen will last for centuries without much deterioration. Specimens document the variation in form and geographical range of species. Herbaria also document valuable historical collections, such as "type specimens", the original specimens on which a plant's Latin name is based. Many herbarium specimens record the existence of plants in habitats now developed and lost.

COLLECTION

Before collecting any seagrass specimens, ensure you have the appropriate permits.

In the field, collect a handful of representative seagrass shoots, including the leaves, rhizomes and roots. Keep in mind that it is not always possible to get a successful classification if you do not have particular parts such as flowers, fruits, seeds and roots, so try to select shoots which have these features. Ideally, collect plants with growing tips (meristems) as they contain higher concentrations of DNA which could aid genetic identification in the future.

Specimens should be pressed as soon as possible after collection. If it is more than 2 hours before you press the specimen, then you should refrigerate to prevent any decomposition. Do not refrigerate longer than 2 days, press the sample as soon as possible.

PRESSING

Tools

First you will need some clean white cartridge-type paper (photocopy paper will suffice) and herbarium sheets (if available). You will also need forceps, scissors/scalpel, a dish of clean fresh water and a herbarium press. It is not difficult to build a home-made press, keeping in mind that what must be accomplished is to keep the specimens squeezed between layers of paper (newspapers or blotting paper) until they are totally devoid of the original content of water. The upper and lower parts of the press might be made of heavy cardboard or thick plywood or equivalent material. A more advanced kind of press might be built for an optimal drying of your plants. This press can be made with two wooden boards with screws and nuts placed at each corner: turning the nuts the two boards will come closer pushing together the paper with the plants. This kind of press can be built at home or bought in some art tools stores.

Preparation

Wash the seagrass specimen in clean fresh water and carefully remove any debris, epiphytes or sediment particles.

Arrangement

It is very important that the seagrass specimen be arranged so that you can immediately see all the main characters of that particular species; so do not focus only at the aesthetics of the mounted specimen. It is advisable to arrange specimens before being placed in the press as once dried, plant specimens can easily be broken if handled without care. The best manner to place the plants on the mounting sheets is to align them with the right side of the page (or diagonally if space is required) and to have the heaviest parts and specimens at the bottom. Leaves can be folded in larger specimens if a larger press is not available. It is better to leave an empty space at the borders of the mounting sheets; but you can either arrange your specimens (along with the label) in a regular way from page to page, or stagger the specimens

at different positions on each sheet, so that each group of sheets will have a more equally distributed pressure.

Labels

Each specimen must have a label on its own sheet, which should include the taxonomic denomination (*at least family, genus and species*) along with information on the date and place of collection. The name of the collector and of the individual who did the determination should also be added. Use permanent and water resistant ink (black or blue) to write your labels; otherwise a pencil can be used (medium lead). Specimen labels should include:

- species name (*if known*)
- location & site code (*if applicable*)
- date collected
- latitude/longitude
- water depth
- % seagrass cover
- sediment type
- other seagrass species present
- name of collector and who identified the specimen
- comments -*such as presence of flowers/fruits or ecological notes*

Place the label on the lower right hand corner of the paper.

Drying

Place another clean sheet of paper over the specimen and place within several sheets of newspaper. As circulating air is very important to get your specimens dried in a short time, the assemblage of specimen/paper should be placed within two sheets of corrugated cardboard and then into a herbarium press. Corrugated cardboard ensures air can penetrate and speed up the drying process. If no corrugated cardboard is available, keep the filled press size small.

Once in the herbarium press, wind down the screws until tight (*do not over tighten*). If you do not have a press, the specimens can be pressed by putting some heavy object on top, i.e. bricks or large books. It is important that the plants are put under sufficient pressure; otherwise more time will be required to achieve a good desiccation, besides they could be damaged by dampness and moulds.



The press should be exposed to a gentle heat source, avoiding excessive heat that will "cook" the specimens. Sometimes it is possible to use the heat from the sun. In this case the presses should be small. If fire is the heat source, keep the press at a safe distance to prevent fire starting on the press.

Changing the paper is a very important step. In the first three or four days a paper change should take place every day, then you can leave more time between changes. If you neglect the change of paper the plants will take more time to lose their water content, besides they could be damaged if the paper stays wet for a few days. When changing the paper you must keep the specimens intact and ensure the label travels with the specimen. The minimum time required for complete drying ranges from two to four days or more. Once a specimen has become dry and stiff, it can be mounted and placed into the herbarium.

Mounting

Once the specimen is completely dry, you will need to mount it to herbarium sheets if available or a new clean white cartridge-type paper.

There are different ways to mount the specimens to the herbarium sheets, such as strapping, gluing, pinning or nothing. We recommend the strapping method using removable adhesive tape (e.g. Magic Tape). The tape pulls off easily, leaves behind no messy residue, and can be pulled up and moved around. To fix the specimen to the mounting paper, lay small strips of tape across a few sturdy parts of the plant (e.g. either end of rhizome or a stem) at a minimal number of points. This method will allow a certain degree of movement for further examinations, but the specimen will not fall from the mounting paper

HERBARIA

Once the specimen is mounted it can be stored in a dry place or lodged in Herbaria. If you do not have a Herbaria in your region or state (usually located at a University or Government agency), you can submit specimens to Seagrass-Watch HQ which maintains a Herbaria as part of the Australia Tropical Herbarium.

Alternatively, you can email a scanned image of the pressed specimen. Please ensure that the scanned image is no less than 600 dpi and includes the specimen and label. Scanned images can be sent to hq@seagrasswatch.org and will be lodged in the Seagrass-Watch Virtual Herbarium <http://www.seagrasswatch.org/herbarium.html>.

The Virtual Herbarium is an electronic gateway to the collections of the Seagrass-Watch HQ herbaria. The goals of the Virtual Herbarium are to make specimen data available electronically for use in biodiversity research projects; to reduce transport of actual specimens for projects where digital representations will suffice for study; and to provide a source of reference information for Seagrass-Watch participants.

Understanding sediment

Seagrasses, especially structurally large species, affect coastal and reef water quality by trapping sediments and acting as a buffer between catchment inputs and reef communities. Seagrass meadows have the ability to modify the energy regimes of their environments, and help stabilise sediment by trapping and binding the sediment. However, the trapping ability of seagrass is in reality an equilibrium established between deposition/sedimentation and erosion/resuspension.

Studies have shown that sediment characteristics are important in determining seagrass growth, germination, survival, and distribution. As part of Seagrass-Watch, field descriptions of sediment type collected 0-2 cm below the sediment/water interface are determined by visual and tactile inspection of (wet) samples and constituents (primary descriptors) differentiated according to the Udden – Wentworth grade scale.

Grain size classes used, based on the Udden – Wentworth grade scale of Wentworth (1922).

	Fine-medium Clay	0 – 0.002 mm
	Coarse Clay	0.0021 – 0.004 mm
Mud	Very Fine Silt	0.0041– 0.008 mm
	Fine Silt	0.0081 – 0.016 mm
	Medium Silt	0.0161 – 0.031 mm
	Coarse Silt	0.0311 – 0.063 mm
	<hr/>	
	Very Fine Sand	0.0631 – 0.125 mm
	Fine Sand	0.1251 – 0.250 mm
Sand	Medium Sand	0.2501 – 0.500 mm
	Coarse Sand	0.5001 – 1.000 mm
	Very Coarse Sand	1.0001 – 2.000 mm
<hr/>		
Gravel	Granules	2.0001 – 4.000 mm
	Pebbles and larger	>4.0001 mm

In Seagrass-Watch, the primary descriptors relate to the size of the sediment grains: gravel (>2000µm); coarse sand (>500 µm); sand (>250 µm); fine sand (>63 µm); and mud (<63 µm).

The sediment **Primary Descriptors** are written down from left to right in decreasing order of abundance: e.g. Mud/Sand is mud with sand, where mud is determined as the dominant constituent (by volume).

mud	<i>has a smooth and sticky texture.</i>
fine sand	<i>fairly smooth texture with some roughness just detectable. Not sticky in nature.</i>
sand	<i>rough grainy texture, particles clearly distinguishable.</i>
coarse sand	<i>coarse texture, particles loose.</i>
gravel	<i>very coarse texture, with some small stones.</i>

Sediment type **Modifiers** are also commonly used, however these are recorded in the comments section. Modifiers include: coral, shell grit, forams, diatoms, etc.

The visual/tactile estimation method used in Seagrass-Watch is a simple yet relatively accurate measure of the sediment grain size which can be used for quantitative assessments (see McKenzie 2007, http://www.seagrasswatch.org/Info_centre/Publications/pdf/371_DPIF_McKenzie.pdf).

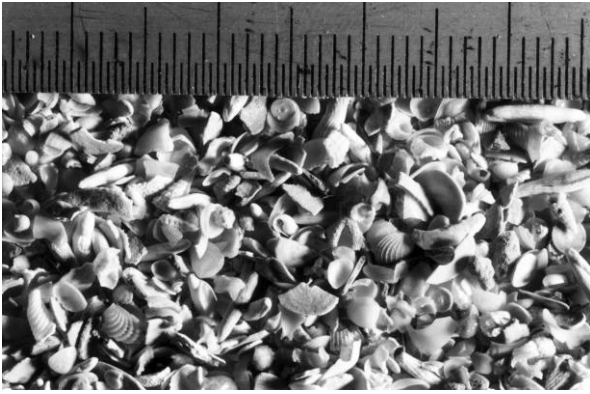

gravel (>2mm)

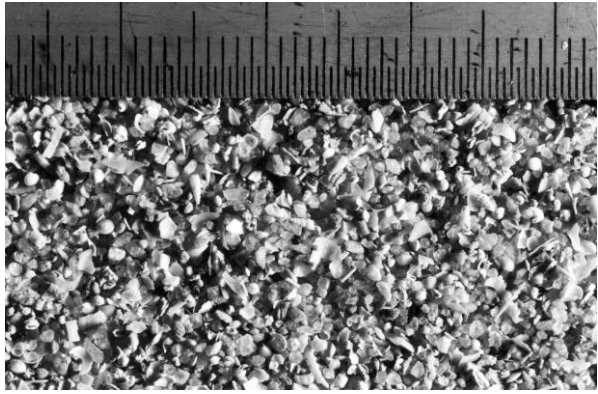

very coarse sand (1 – 2 mm)

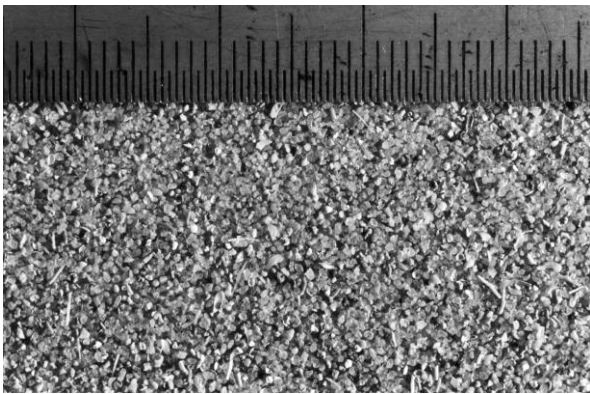

coarse sand (0.5 – 1 mm)

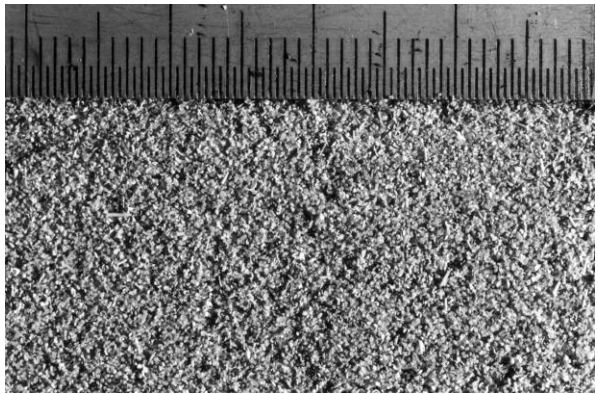

medium sand (0.25 – 0.5 mm)

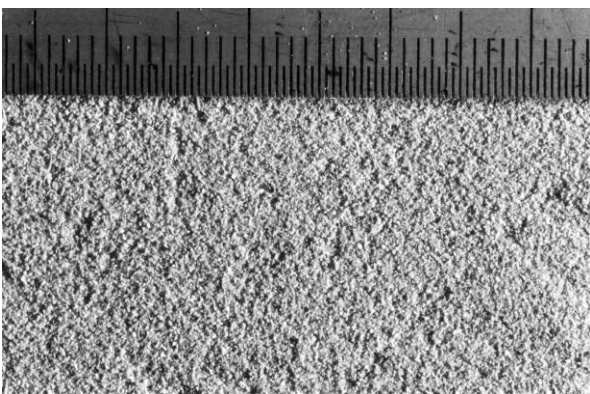

fine sand (0.125 – 0.25 mm)

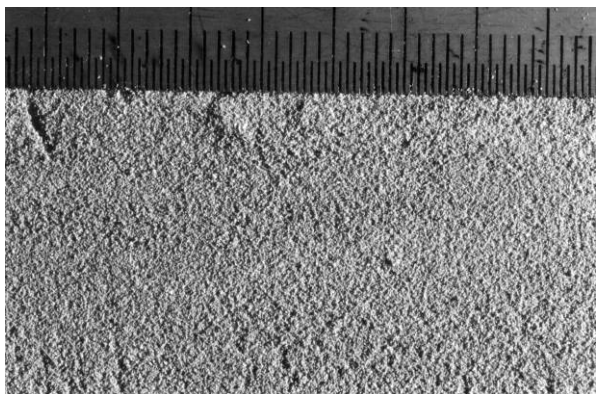

very fine sand (0.063 – 0.125mm)

Notes:

.....

.....

.....

.....

.....

Managing seagrass resources

Threats to seagrass habitats

Destruction or loss of seagrasses have been reported from most parts of the world, often from natural causes, e.g., "wasting disease" or high energy storms. However, destruction commonly has resulted from human activities, e.g., as a consequence of eutrophication or land clamation and changes in land use. Increases in dredging and landfill, construction on the shoreline, commercial overexploitation of coastal resources, and recreational boating activities along with anthropogenic nutrient and sediment loading has dramatically reduced seagrass distribution in some parts of the world. Anthropogenic impacts on seagrass meadows continue to destroy or degrade coastal ecosystems and decrease the function and value of seagrass meadows including their contribution to fisheries. It is possible global climate change will have a major impact. Efforts are being made toward rehabilitation of seagrass habitat in some parts of the world: transplantation, improvement of water quality, restrictions on boating activity, fishing and aquaculture, and protection of existing habitat through law and environmental policy.

Management

Seagrasses do not exist in nature as a separate ecological component from other marine plants and are often closely linked to other community types. In the tropics the associations are likely to be complex interactions with mangrove communities and coral reef systems. In temperate waters, algae beds, salt marshes, bivalve reefs, and epiphytic plant communities are closely associated with areas of seagrass. Many management actions to protect seagrasses have their genesis in the protection of wider ecological systems or are designed to protect the overall biodiversity of the marine environment.

Seagrasses are also food for several marine mammal species and turtles, some of which (such as the dugong *Dugong dugon* and green turtle *Chelonia mydas*) are listed as threatened or vulnerable to extinction in the IUCN Red List (www.iucnredlist.org). Seagrasses are habitat for juvenile fish and crustaceans that in many parts of the world form the basis of economically valuable subsistence and/or commercial fisheries. The need to manage fisheries in a sustainable way has itself become a motivating factor for the protection of seagrasses.

Methods of direct protection range from legislative instruments and associated legal sanctions through to education (Coles & Fortes 2001). These can be separated into three approaches: a proscriptive legal approach; a non-proscriptive broad based approach ranging from planning processes to education; and a reactive approach designed to respond to a specific issue such as a development proposal. These may overlap and be used simultaneously in many cases. It is these three approaches that Seagrass-Watch supports for the protection/conservation of seagrass.

Reactive (on-ground)

Reactive processes generally occur in response to a perceived operational threat such as a coastal development proposal (Coles & Fortes 2001). Reactive processes can include port contingency planning, risk management plans and environmental impact assessments.

Prescriptive (legal)

Prescriptive management of seagrass issues can range from local laws to a Presidential Decree, or Executive Order. Laws can directly safeguard seagrasses

or can protect them indirectly by protecting habitat types (all aquatic vegetation) or by influencing a process, e.g., prevention of pollution (Coles & Fortes 2001).

In some locations, protection is often strongest at the village or community level. This may be by Government supported agreements or through local management marine area level. In these cases successful enforcement is dependent on community support for the measure.

Non-prescriptive (planning & education)

Non-prescriptive methods of protecting seagrasses are usually part of planning processes and may have a strong extension/education focus (Coles & Fortes 2001). Providing information is important as it enables individuals to voluntarily act in ways that reduce impacts to seagrasses. Non-prescriptive methods range from simple explanatory guides to complex industry codes of practice.

Coastal management decision making is complex, and much of the information on approaches and methods exists only in policy and legal documents that are not readily available. There may also be local or regional Government authorities having control over smaller jurisdictions with other regulations and policies that may apply. Many parts of South East Asia and the Pacific Island nations have complex issues of land ownership and coastal sea rights. These are sometimes overlaid partially by arrangements put in place by colonising powers during and after World War II, leaving the nature and strength of protective arrangements open for debate.

Both Australia and the United States have developed historically as Federations of States with the result that coastal issues can fall under State or Federal legislation depending on the issue or its extent. In contrast, in Europe and much of South East Asia, central Governments are more involved. Intercountry agreements in these areas such as the UNEP Strategic Action Plan for the South China Sea and the Mediterranean Countries Barcelona Convention (<http://www.unep.org/>) are required to manage marine issues that encompass more than one country.

Approaches to protecting seagrass tend to be location specific or at least nation specific (there is no international legislation directly for seagrasses as such that we know of) and depend to a large extent on the tools available in law and in the cultural approach of the community. There is, however, a global acceptance through international conventions (RAMSAR Convention; the Convention on Migratory Species of Wild Animals; and the Convention on Biodiversity) of the need for a set of standardised data/information on the location and values of seagrasses on which to base arguments for universal and more consistent seagrass protection.

Indigenous concepts of management of the sea differ significantly from the introduced European view of the sea as common domain, open to all and managed by governments (Hardin 1968). Unlike contemporary European systems of management, indigenous systems do not include jurisdictional boundaries between land and sea. Indigenous systems have a form of customary ownership of maritime areas that has been operating in place for thousand of years to protect and manage places and species that are of importance to their societies.

Marine resource management these days should, therefore, attempt to achieve the following interrelated objectives: a) monitor the wellbeing (e.g. distribution, health and sustainability) of culturally significant species and environments (e.g. dugong, marine turtles, fish, molluscs, seagrass etc.); and b) monitor the cultural values associated with these culturally significant species and environments (Smyth *et al.* 2006).

To realize objective a) we believe the following also needs to be accomplished if the successful management of coastal seagrasses is to be achieved.

1. Important fish habitat is known and mapped
2. Habitat monitoring is occurring
3. Adjacent catchment/watershed impacts and other threats are managed
4. Some level of public goodwill/support is present
5. Legal powers exist that are robust to challenge
6. There is effective enforcement and punishment if damage occurs

The key element is a knowledge base of the seagrass resource that needs to be protected and how stable/variable that resource is. It is also important to know if possible any areas that are of special value to the ecosystems that support coastal fisheries and inshore productivity. It is important as well that this information is readily available to decision makers in Governments in a form that can be easily understood.

Consequently a combination of modern “western” science and indigenous knowledge should be brought together within a co-management framework for the successful management of these resources. (Johannes 2002; Aswani & Weiant 2004; Turnbull 2004; Middlebrook and Williamson 2006; Gaskell 2003, George et al. 2004). This can only occur if the resource owners actively involve themselves in the management of their resources. Western science also needs to recognise that resource owners have practical and spiritual connections with the resources found within their environment. Once this is recognized then this approach will have the added benefit of empowering communities who own the knowledge to be the primary managers and leaders in decisions about their land and sea country.

References

- Aswani, S., Weiant, P. (2004). Scientific evaluation in women's participatory management: monitoring marine invertebrate refugia in the Solomon Islands. *Human Organisation* **63** (3), 301-319.
- Beumer, J., Carseldine, L. & Zeller, B. (1997). Declared Fish Habitat Areas in Queensland. *Information Series* QI97004. Queensland Department of Primary Industries, 178pp.
- Coles R.G. and Fortes, M. (2001) Protecting seagrass - approaches and methods. In Short, F.T. and Coles, R.G. (eds) 2001. *Global Seagrass Research Methods*. Elsevier Science B.V., Amsterdam. Chapter 23, pp. 446-463.
- Coles RG, Lee Long WJ, Watson RA and Derbyshire KJ (1993). Distribution of seagrasses, and their fish and penaeid prawn communities, in Cairns Harbour, a tropical estuary, northern Queensland, Australia. *Australian Journal of Marine and Freshwater Research* **44**: 193 – 210
- Coles RG, McKenzie LJ and Campbell SJ. (2003). The seagrasses of eastern Australia. Chapter 11 In: *World Atlas of Seagrasses*. (EP Green and FT Short eds) Prepared by the UNEP World Conservation Monitoring Centre. (University of California Press, Berkeley. USA). pp 119-133.
- Costanza R, d'Arge R, de Groot R, Farber S, Grasso M, Hannon B, Limburg K, Naeem S, O'Neil RV, Paruelo J, Raskin RG, Sutton P and van der Belt M. (1997). The Value of the world's ecosystem services and natural capital. *Nature* **387**(15): 253-260.
- Gaskell, J. (2003). Engaging science education within diverse cultures. *Curriculum Inquiry*. **33**: 235-249.
- George, M., Innes, J., Ross, H. (2004). Managing sea country together: key issues for developing co-operative management for the Great Barrier Reef World Heritage Area. CRC Reef Research Centre Technical Report No 50, CRC Reef Research Centre Ltd, Townsville.
- Hardin, G. (1968). The tragedy of the commons. *Science, New Series* **162** (3859), 1243-1248.
- Hyland, S.J., Courtney, A.J. and Butler, C.T. (1989). Distribution of seagrass in the Moreton Region from Coolangatta to Noosa. *Information Series* QI89010. Queensland Department of Primary Industries, Brisbane. 178pp
- Johannes, R.E. (2002). The renaissance of community-based marine resource management in Oceania. *Annu. Rev. Ecol. Syst.* **33**: 317-340.
- King, L. (2008) Noosa roundup. *Seagrass-Watch News* 34: 9
- Marsh, H. and Lawler, I. (2001) Dugong distribution and abundance in the southern Great Barrier Reef Marine Park and Hervey Bay: Results of an aerial survey in October- December 1999. Report to Great Barrier Reef Marine Park Authority.
- Masel, J.M. and Smallwood, D.G. (2000). Habitat usage by postlarval and juvenile prawns in Moreton Bay, Queensland, Australia. *Proceedings of the Royal Society of Queensland*. **109**: 107-117.
- McKenzie, LJ. (2007) Relationships between seagrass communities and sediment properties along the Queensland coast. Progress report to the Marine and Tropical Sciences Research Facility. Reef and Rainforest Research Centre Ltd, Cairns. 25pp.
- McKenzie, L.J., Lee Long, W.J., Coles, R.G. and Roder, C.A. (2000). Seagrass-Watch: Community based monitoring of seagrass resources. *Biol. Mar. Medit.* **7**(2): 393-396.



- McKenzie, L.J., Campbell, S.J., Vidler, K.E. & Mellors, J.E. (2007) *Seagrass-Watch: Manual for Mapping & Monitoring Seagrass Resources*. Seagrass-Watch HQ, Cairns. 114pp
- Middlebrook, R., Williamson, J.E. (2006). Social attitudes towards marine resource management in two Fijian villages. *Ecological Management & Restoration* **7**(2): 144-147.
- Phillips, J.A, Koskela, T.V., Koskela, R. and Collins, D. (2008). The seagrass halophila minor newly recorded from Moreton Bay. *Memoirs of the Queensland Museum - Nature*. **54**(1): 421-426.
- Smyth, D., Fitzpatrick, J., Kwan, D. (2006). Towards the development of cultural indicators for marine resource management in Torres Strait. CRC Torres Strait, Townsville. 61 pp.
- Turnbull, J. (2004). Explaining complexities of environmental management in developing countries: lessons from the Fiji Islands. *The Geographical Journal* **170** (1), 64–77.
- Waycott, M, McMahon, K, Mellors, J., Calladine, A., and Kleine, D (2004) A guide to tropical seagrasses in the Indo-West Pacific. (James Cook University Townsville) 72pp.
- Williams, L.E. (1997). Queensland's Fisheries Resources: current condition & recent trends 1988-1995. *Queensland Department of Primary Industries Information Series QI97007*.100.pp.
- Zeller, B. (1998). Queensland's Fisheries Habitats, Current Condition and Recent Trends. *Queensland Department of Primary Industries Information Series QI98025*. 211pp.

Further reading:

- den Hartog C. (1970). The seagrasses of the world. (North-Holland Publishing, Amsterdam). 293pp.
- Green EP. and Short FT (Eds) (2003). World Atlas of Seagrasses. Prepared by the UNEP World Conservation Monitoring Centre. (University of California Press, Berkeley. USA). 298pp.
- Lanyon JM, Limpus CJ and Marsh H. (1989). Dugongs and turtles: grazers in the seagrass system. In: Biology of Seagrasses: A treatise on the biology of seagrasses with special reference to the Australian region. (AWD Larkum, AJ McComb and SA Shepherd eds). (Elsevier: Amsterdam, New York). pp 610-34.
- Larkum AWD, Orth RJ and Duarte CM (2006). Seagrasses: biology, ecology and conservation. Springer, The Netherlands. 691 pp.
- Orth RJ, Carruthers TJB, Dennison WC, Duarte CM, Fourqurean JW, Heck Jr KL, Hughes AR, Kendrick GA, Kenworthy WJ, Olyarnik S, Short FT, Waycott M and Williams SL. (2006). A Global Crisis for Seagrass Ecosystems. *BioScience* 56 (12): 987-996.
- Lee Long, W. J., Coles, R. G. & McKenzie, L. J. (2000) Issues for seagrass conservation management in Queensland. *Pacific Conservation Biology* 5, 321-328.
- Marsh, H., O'Shea, T.J., Reynolds III, J.E. (2011) Ecology and Conservation of the Sirenia: Dugongs and Manatees. Cambridge University Press, New York. 536pp
- Phillips, R.C, E.G Menez. (1988). Seagrasses. Smithsonian Institution Press, Washington, D.C. 104 pp.
- Poiner, I.R., Walker, D.I., and Coles, R.G. (1989). Regional Studies - Seagrass of Tropical Australia. In: Biology of Seagrasses. A.W.D. Larkum, A-J. McComb and S.A.Sherpherd (Eds). Elsevier, Amsterdam, New York; 841 pp.
- Short, FT and Coles, RG. (Eds.) Global Seagrass Research Methods. Elsevier Science B.V., Amsterdam. 473pp.



Useful web links

Seagrass-Watch Official Site www.seagrasswatch.org

Seagrass Adventures Interactive website designed by students from Bentley Park College in Cairns (Australia). Website includes games, puzzles and quizzes for students to learn about seagrass and their importance. www.reef.crc.org.au/seagrass/index.html

World Seagrass Association A global network of scientists and coastal managers committed to research, protection and management of the world's seagrasses. wsa.seagrassonline.org

Seagrass Outreach Partnership Excellent website on seagrass of Florida. Provides some background information on seagrasses and has a great section with educational products and Seagrass Activity Kit for schools. www.flseagrass.org

Seagrass forum A global forum for the discussion of all aspects of seagrass biology and the ecology of seagrass ecosystems. Because of their complex nature, discussion on all aspects of seagrass ecosystems is encouraged, including: physiology, trophic ecology, taxonomy, pathology, geology and sedimentology, hydrodynamics, transplanting/restoration and human impacts. www.science.murdoch.edu.au/centres/others/seagrass/seagrass_forum.html

Reef Guardians and ReefEd Education site of the Great Barrier Reef Marine Park Authority. Includes a great collection of resources about the animals, plants, habitats and features of the Great Barrier Reef. Also includes an on-line encyclopedia, colour images and videos for educational use, a range of free teaching resources and activities. www.reefed.edu.au

Integration and Application Network (IAN) A website by scientists to inspire, manage and produce timely syntheses and assessments on key environmental issues, with a special emphasis on Chesapeake Bay and its watershed. Includes lots of helpful communication products such as fact sheets, posters and a great image library. ian.umces.edu

Reef Base A global database, information system and resource on coral reefs and coastal environments. Also extensive image library and online Geographic Information System (ReefGIS) which allows you to display coral reef and seagrass related data on interactive maps. www.reefbase.org

UNEP - World Conservation Monitoring Centre Explains the relationship between coral reefs, mangroves and seagrasses and contains world distribution maps. www.unep-wcmc.org

for more links, visit www.seagrasswatch.org/links.htm

Notes:

.....

.....

.....

.....

.....

.....

.....

.....

.....

.....

.....

.....

.....

.....

.....

.....

.....

.....

.....

.....

.....

.....

.....

We value your suggestions and any comments you may have to improve the Seagrass-Watch program.

Please complete the following statements in your own words

I found the Seagrass-Watch training to be

.....
.....

What I enjoyed most about the training was

.....
.....

It could have been better if

.....
.....

I did not realize that

.....
.....

Now I understand that

.....
.....

In my area the types of seagrasses and habitats include

.....
.....

When I go back to my area, I will.....

.....

.....

.....

Other comments

.....

.....

.....

.....

.....

.....

.....

.....

.....

.....

.....

.....

.....

.....

.....

.....

Please hand in your form once you have completed it.



Thank you