



# Seagrass-Watch

Proceedings of a workshop for monitoring  
seagrass habitats in the Kimberley region,  
Western Australia

*Department of Environment & Conservation - West Kimberly Office  
Broome, Western Australia  
15-16 October 2011*

Len McKenzie & Rudi Yoshida

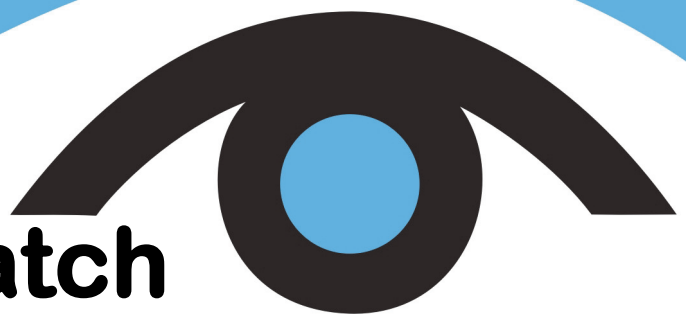

First Published 2011

©Seagrass-Watch HQ, 2011

Copyright protects this publication.

Reproduction of this publication for educational or other non-commercial purposes is authorised without prior written permission from the copyright holder provided the source is fully acknowledged.

Reproduction of this publication for resale or other commercial purposes is prohibited without prior written permission of the copyright holder.

#### *Disclaimer*

Information contained in this publication is provided as general advice only. For application to specific circumstances, professional advice should be sought.

Seagrass-Watch HQ has taken all reasonable steps to ensure the information contained in this publication is accurate at the time of the survey. Readers should ensure that they make appropriate enquires to determine whether new information is available on the particular subject matter.

The correct citation of this document is

*McKenzie, LJ & Yoshida, R.L. (2011). Seagrass-Watch: Proceedings of a workshop for monitoring seagrass habitats in the Kimberley region, Western Australia. Department of Environment & Conservation - West Kimberley Office, Broome, 15 - 16 October 2011. (Seagrass-Watch HQ, Cairns). 66pp.*

Produced by Seagrass-Watch HQ

Front cover photos (left to right): Monitoring RO1 with dugong feeding trails (Sep10) by Len McKenzie, *Halophila ovalis* and *Halodule uninervis* (RO1) by Rudi Yoshida and Town Beach by Len McKenzie,

Enquires should be directed to:

Len McKenzie  
Seagrass-Watch Program Leader  
Northern Fisheries Centre,  
PO Box 5396  
Cairns, QLD 4870 Australia



Department of  
Environment and Conservation



# Table of Contents

<b>OVERVIEW .....</b>	<b>5</b>
<b>WORKSHOP LEADERS .....</b>	<b>7</b>
<b>AGENDA - LEVEL 1 (BASIC) .....</b>	<b>8</b>
SATURDAY 15 <sup>TH</sup> OCTOBER 2011 .....	8
SUNDAY 16 <sup>TH</sup> OCTOBER 2011 (TOWN BEACH).....	8
<b>BACKGROUND.....</b>	<b>9</b>
<b>INTERESTING FACTS:.....</b>	<b>17</b>
<b>SEAGRASS IN THE KIMBERLEY REGION OF WESTERN AUSTRALIA .....</b>	<b>19</b>
<i>ROEBUCK BAY</i> .....	20
<i>CABLE BEACH TO QUONDONG POINT</i> .....	22
<i>QUONDONG POINT TO COULOMB POINT</i> .....	22
<i>COULOMB POINT TO BEAGLE BAY</i> .....	23
<i>BEAGLE BAY TO CAPE BORDA (INCLUDING PERPENDICULAR HEAD)</i> .....	23
<i>CAPE BORDA TO CAPE LEVEQUE</i> .....	23
<i>KING SOUND REGION</i> .....	24
<i>KING SOUND TO NT BORDER</i> .....	26
<b><i>SEAGRASS-WATCH IN THE KIMBERLEY REGION</i></b> .....	27
ROEBUCK BAY .....	27
DAMPIER PENINSULA.....	30
<b>A GUIDE TO THE IDENTIFICATION OF TROPICAL WESTERN AUSTRALIA'S SEAGRASSES .....</b>	<b>31</b>
<b>PARTS OF A SEAGRASS PLANT.....</b>	<b>33</b>
<b>MONITORING A SEAGRASS MEADOW .....</b>	<b>35</b>
<b>HOW TO USE A COMPASS.....</b>	<b>43</b>
<b>MAKING A HERBARIUM PRESS SPECIMEN .....</b>	<b>46</b>
<b>UNDERSTANDING SEDIMENT .....</b>	<b>53</b>
<b>DATA ENTRY.....</b>	<b>55</b>
<b>MANAGING SEAGRASS RESOURCES .....</b>	<b>57</b>
THREATS TO SEAGRASS HABITATS .....	57
MANAGEMENT .....	57
<i>Reactive (on-ground)</i> .....	57
<i>Prescriptive (legal)</i> .....	57
<i>Non-prescriptive (planning &amp; education)</i> .....	58
<b>REFERENCES .....</b>	<b>61</b>

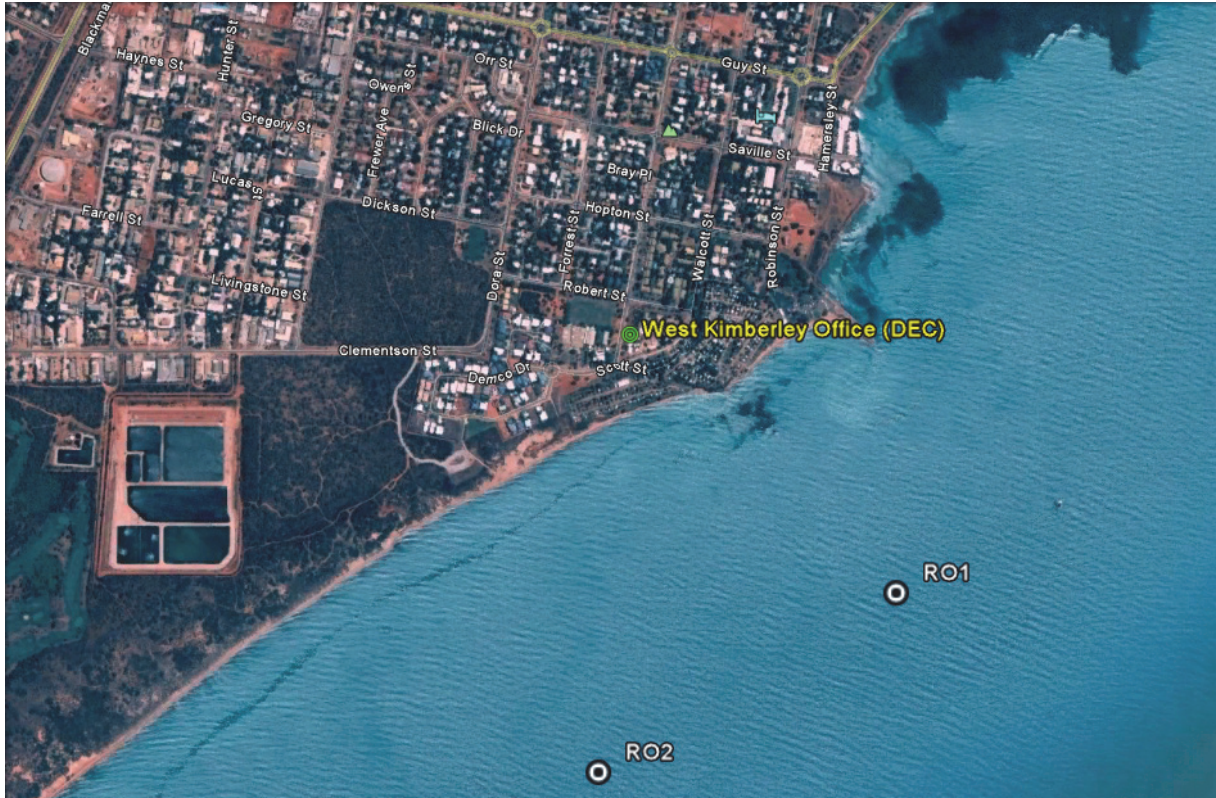

Department of Environment & Conservation - West Kimberley Office,  
111 Herbert Street, Broome, Western Australia  
*Telephone: (08) 9195 5500*

# Overview

Seagrass-Watch is a participatory monitoring program developed in 1998 to provide an early warning of coastal ecological decline. Anyone can participate in Seagrass-Watch, as it responds to local needs. Program participants include scientists, rangers and volunteers (e.g., local residents, indigenous groups, tertiary institutions, non-government organisations). Seagrass-Watch is a monitoring program that brings people together for seagrass conservation. Participants range in ages from 18 to 68 and represent a diverse cross-section of the community, including tradespeople, engineers, school teachers, fishers, divers, retirees, high school and university students, biologists and ecologists. Many are involved with local environmental groups and have a keen interest in conservation and environmental issues.

Seagrass-Watch is a global scientific, non-destructive, seagrass assessment and monitoring program. It identifies areas important for seagrass species diversity and conservation. The information collected can be used to assist the management of coastal environments and to prevent significant areas and species being lost.

Monitoring seagrass resources is important for two reasons: it is a valuable tool for improving management practices; and it allows us to know whether resource status and condition is stable, improving or declining. Successful management of coastal environments (*including seagrass resources*) requires regular monitoring of the status and condition of natural resources.

Early detection of change allows coastal management agencies to adjust their management practices and/or take remedial action sooner for more successful results. Monitoring is important in improving our understanding of seagrass resources and to coastal management agencies for:

- *exposing coastal environmental problems before they become intractable,*
- *developing benchmarks against which performance and effectiveness can be measured,*
- *identifying and prioritising future requirements and initiatives,*
- *determining the effectiveness of management practices being applied,*
- *maintaining consistent records so that comparisons can be made over time,*
- *developing within the community a better understanding of coastal issues,*
- *developing a better understanding of cause and effect in land/catchment management practices,*
- *assisting education and training, and helping to develop links between local communities, schools and government agencies, and*
- *assessing new management practices.*

Seagrass-Watch monitoring efforts are vital to assist with tracking global patterns in seagrass health, and assess the human impacts on seagrass meadows, which have the potential to destroy or degrade these coastal ecosystems and decrease their yield of natural resources. Responsive management based on adequate information will help to prevent any further significant areas and species being lost. To protect the valuable seagrass meadows along our coasts, everyone must work together.

The goals of the Seagrass-Watch program are:

- *to educate the wider community on the importance of seagrass resources*
- *to raise awareness of coastal management issues*
- *to build the capacity of local stakeholders in the use of standardised scientific methodologies*
- *to conduct long-term monitoring of seagrass & coastal habitat condition*
- *to provide an early warning system of coastal environment changes for management*
- *to support conservation measures which ensure the long-term resilience of seagrass ecosystems.*

This workshop is jointly hosted by Environs Kimberley and the Department of Environment and Conservation, with local coordination by Kylie Weatherall and Julia Rau (Broome Community Seagrass Monitoring Project) and supported by *Coast2Reef* etc and Seagrass-Watch HQ. As part of this Level 1 workshop we will:

- *learn seagrass taxonomy*
- *discuss the present knowledge of seagrass ecology,*
- *discuss the threats to seagrasses*
- *learn techniques for monitoring seagrass resources, and*
- *provide examples of how Seagrass-Watch assists with the management of impacts to seagrass resources and provides an understanding of their status and condition.*

The following information is provided as a training guide and a reference for future Seagrass-Watch monitoring activities. For further information, please do not hesitate to contact us at

**Seagrass-Watch HQ**

Northern Fisheries Centre  
PO Box 5396  
Cairns QLD 4870  
AUSTRALIA  
E-mail [hq@seagrasswatch.org](mailto:hq@seagrasswatch.org)

*or visit*

**[www.seagrasswatch.org](http://www.seagrasswatch.org)**



Photo: Jurgen Freund.

# Workshop leaders



## Len McKenzie

Len is a Principal Scientist with Fisheries Queensland (a service of the Department of Employment, Economic Development and Innovation) and Seagrass-Watch Program Leader. He is also the Task Leader of the Reef Rescue Marine Monitoring Program – Intertidal Seagrass Monitoring and project leader for a series of projects involving the assessment and sustainable use of coastal fisheries habitats. Len has over 20 years experience as a research scientist on seagrass ecology, assessment and fisheries habitats. This includes experience within Australia and internationally in seagrass research, resource mapping/ assessment and biodiversity. He has provided information on seagrass communities that has been vital in management of seagrass resources of the Great Barrier Reef and at the state, national and international levels. He has also advised on fisheries and coastal resource-use issues for managers, fishing organisations, conservation and community groups. Len is a qualified trainer and assessor (TAE40110). Len is also the Secretary of the World Seagrass Association.

### **Current Projects**

- Seagrass-Watch
- Status and mapping of seagrass resources in Queensland
- Condition, trend and risk in coastal habitats: Seagrass indicators, distribution and thresholds of potential concern
- Identification of indicators and thresholds of concern for water quality and ecosystem health on a bioregional scale for the Great Barrier Reef
- Assessment of primary and secondary productivity of tropical seagrass ecosystems
- Investigations on the macrofauna associated with seagrass meadows
- Great Barrier Reef Water Quality Protection Plan – Reef Rescue Marine Monitoring Program: seagrass



## Rudi Yoshida

Rudi is a Scientific Assistant with Fisheries Queensland (a service of the Department of Employment, Economic Development and Innovation). Rudi has over 13 years experience in seagrass related research and monitoring. He is also a core member of Seagrass-Watch HQ, and ensures data submitted is managed and QA/QC protocols applied. He is also responsible for maintenance of the Seagrass-Watch website.

### **Current Projects**

- Seagrass-Watch
- Great Barrier Reef Water Quality Protection Plan – Reef Rescue Marine Monitoring Program: seagrass

# Agenda - Level 1 (*basic*)

## Saturday 15<sup>th</sup> October 2011

<b>Morning</b>	0915 - 0930 (15min)	Welcome & Introduction
	0930 - 0950 (20min)	Seagrass Biology and Identification
	0950 - 1030 (40min)	<b>Classroom activity:</b> Seagrass Identification
	1030 - 1045 (15min)	<i>Break</i>
	1045 - 1115 (30min)	Seagrass Identification <i>continued</i>
	1115 - 1130 (15min)	<b>Classroom activity:</b> how to prepare a seagrass press specimen
	1130 - 1230 (60min)	Seagrass Biology 2 and Ecology
<b>Afternoon</b>	1230 - 1330	<i>Lunch</i>
	1330 - 1400 (30min)	Seagrass importance
	1400 - 1445 (45min)	Seagrass threats
		<b>Classroom activity:</b> Seagrass threats
	1445 - 1500 (15min)	Seagrass monitoring
	1500 - 1600 (60min)	Seagrass-Watch: how to sample
	1600 - 1645 (45min)	Seagrass-Watch: how data is used
	1645 - 1700 (15min)	<i>Wrap-up for day</i>

## Sunday 16<sup>th</sup> October 2011 (Town Beach)

	0600 - 0615 (15min)	Safety briefing & risk assessment
	0615 - 0815 (2hrs)	<b>Field exercise:</b> Seagrass-Watch monitoring
		<i>Where:</i> Town Beach (RO1)
		<ul style="list-style-type: none"> <li>• <i>meet at Town Beach car park</i></li> <li>• <i>be punctual</i></li> <li>• <i>be well rested</i></li> </ul>
		<i>What to bring:</i>
		<ul style="list-style-type: none"> <li>• <i>hat, sunscreen (Slip! Slop! Slap!)</i></li> <li>• <i>dive booties or old shoes that can get wet</i></li> <li>• <i>drink/refreshments and energising snack</i></li> <li>• <i>wet weather gear: poncho/raincoat</i></li> <li>• <i>insect repellent</i></li> <li>• <i>polaroid sunglasses (not essential)</i></li> <li>• <i>simple medical kit in case of injuries to yourself</i></li> <li>• <i>change of footwear and clothes</i></li> <li>• <i>enthusiasm</i></li> </ul>
		<i>You will be walking across a seagrass meadow exposed with the tide, through shallow water.</i>
	0815 - 0830	Wrap up ( <i>on foreshore</i> )
		<ul style="list-style-type: none"> <li>• check gear</li> <li>• feedback</li> </ul>

*Low tide: 1.3m at 638am*



# Background

Seagrasses are unique flowering plants that have evolved to live in sea water. Seagrasses belong to a group of plants known as **angiosperms** (flowering plants).

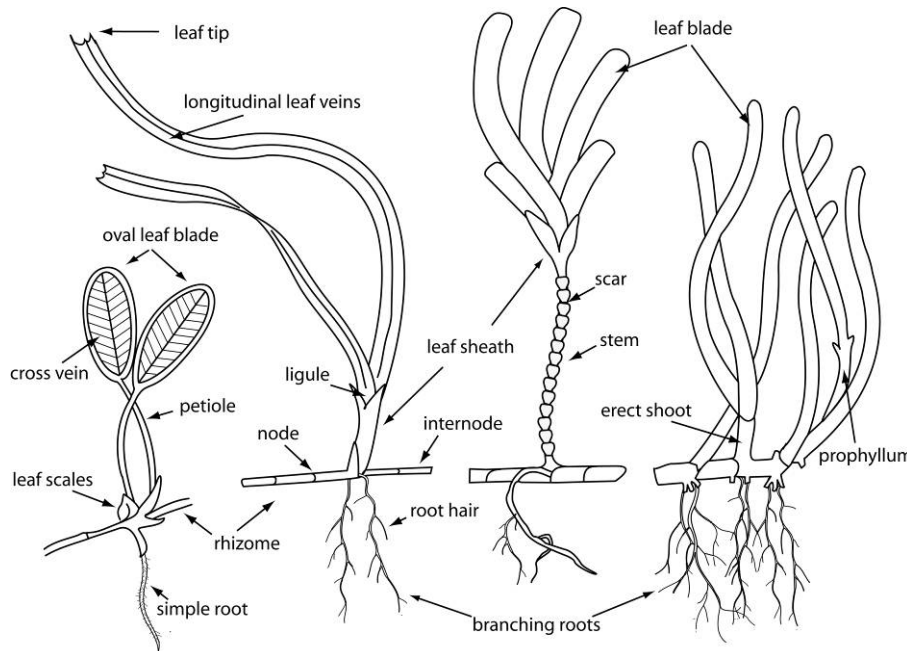

Composite illustration demonstrating morphological features used to distinguish main seagrass taxonomic groups.

Various common names are applied to seagrass species, such as turtle grass, eelgrass, tape grass, spoon grass and shoal grass. These names are not consistently applied among countries. Coastal communities would almost certainly recognise the term “turtle grass” as referring to the shallow subtidal and intertidal seagrasses that turtles are associated with.

Like terrestrial (land living) plants, a seagrass can be divided into its **veins** (lignified conducting tissue that **transports food, nutrients and water around the plant**), stem, roots (buried in the substrate) and reproductive parts such as flowers and fruits. Algae do not have veins in their leaves nor do they possess roots (anchoring to the surface of the substrate by a holdfast) or produce flowers or seeds.

They are called “seagrass” because most have ribbon-like, grassy leaves. There are many different kinds of seagrasses and some do not look like grass at all. Seagrass range from the size of your fingernail to plants with leaves as long as 7 metres. Some of the shapes and sizes of leaves of different species of seagrass include an oval (paddle or clover) shape, a fern shape, a long spaghetti like leaf and a ribbon shape. Species that have a paddle or fern shaped leaf are called *Halophila*. Ones that have a ribbon shaped leaf are the *Cymodocea*, *Thalassia*, *Thalassodendron*, *Halodule* and *Zostera*. Spaghetti-like seagrass is called *Syringodium*. At the base of a leaf is a sheath, which protects young leaves. At the other end of a leaf is the tip, which can be rounded or pointed. The vertical stem, found in some species, is the upright axis of the plant from which leaves arise (attach). The **remnants of leaf attachment** are seen as **scars**.

Seagrass leaves lack stomata (microscopic pores on the under side of leaves) but have thin cuticle to allow gas and nutrient exchange. They also possess

Seagrass are marine flowering plants

Seagrasses have roots, stems and leaves

Seagrass is different to seaweed (algae) as they have internal veins, true roots and produce flowers, fruits and seeds

Leaves of different seagrass species can be shaped like a flattened ribbon, look like a fern, round like a clover, or even spaghetti shaped



large thin-walled aerenchyma. The aerenchyma are commonly referred to as veins as they carry water and nutrients throughout the plant (i.e. an **internal vascular system**). Aerenchyma is specialized tissue having a regular arrangement of air spaces, called lacunae, that both provides buoyancy to the leaves and facilitate gas exchange throughout the plant. Leaves have a very thin cuticle, which allows gas and some nutrient diffusion into them from the surrounding water. Veins can be across the leaf blade or run parallel to the leaf edge. Also within the leaves are chloroplasts, which use the sun's light to convert carbon dioxide and water into oxygen and sugar (photosynthesis). The sugar and oxygen are then available for use by other living organisms.

The roots and horizontal stems (**rhizomes**) of seagrass are often buried in sand or mud. They **anchor the plant, store carbohydrates and absorb nutrients**. Roots can be simple or branching and all have fine hairs to help absorb nutrients. Rhizomes are formed in segments with leaves or vertical stems rising from the joints, called **nodes** or scars. Sections between the nodes are called internodes. Seagrasses depend upon the growth of rhizomes to increase the area they occupy. This vegetative growth is the most common mode of growth for seagrasses. Although the rhizome mainly runs horizontally, some lateral branches are more or less erect and bear leaves (erect shoots). Sometimes the leaves are on a special type of stalk, called a petiole.

The Roots and Rhizomes of seagrasses are well endowed with aerenchyma and the lacunae are extensive and continuous with leaf tissues. **Oxygen** transport to the roots creates an oxic environment around the roots, facilitating nutrient uptake.

Seagrasses have flowers and pollination systems that are well adapted for pollination by water. **Seagrass form tiny flowers, fruits and seeds**. Most seagrasses have separate male and female plants. In most species, flowers are small, white and are borne at the base of the leaf clusters. The stamens (male parts) and pistils (female parts) extend above the petals to facilitate pollen release and pollination respectively.

Most seagrasses reproduce by pollination while submerged and complete their entire life cycle underwater. Pollination in seagrasses is hydrophilic (aided by water), and can occur by: (i) pollen transported above water surface (e.g., *Enhalus*); (ii) pollen transported on water surface (e.g., *Halodule*), or; (iii) pollen transported beneath water surface (e.g., *Thalassia*).

Seagrass pollen grains are elongated into a filamentous shape. The filamentous nature of pollen grains facilitates transport within the water medium, **mainly by water currents**. *Halophila* and *Thalassia* have spherical pollen grains, but they remain joined together in long chains, giving the same effect as having elongated, filamentous pollen grains.

After fertilization, the ovary of the female flower develops into a fruit. In seagrasses, fruit development and fruit structure are as diversified as their flowering patterns and floral structures. In general the seeds, ranging in the size from 0.3 to 0.5mm in some *Halophila* species to more than 1–2 cm in *Enhalus*, are furnished with a nutrition reserve and sink rather than float. The **number of seeds within a fruit also varies from 1 (eg *Halodule uninervis*) up to 25 (eg *Halophila ovalis*)**.

Seagrass have veins and air channels in their leaves and stems so they can carry water, food and absorb gases

Seagrasses rely on light to convert carbon dioxide and water into oxygen and sugar (photosynthesis)

Roots can be simple or branching and all have fine hairs to help absorb nutrients

Seagrass pump oxygen into the sediment via their roots

Seagrass have flowers, fruits and seeds

Pollination occurs in the water

Pollen from male seagrass flowers is mainly dispersed to female seagrass flowers by tidal currents

Seagrasses are not true grasses

Seagrasses are more closely related to lilies



### Seagrass taxonomy

Seagrasses are monocotyledons that are not true grasses (true grasses belong to the family Poaceae), but are rather more closely related to the lily family.

Seagrasses evolved approximately **100 million years ago** from land plants that returned to the sea in a least three separate lineages or families. Thus, seagrasses are not a taxonomically unified group but a 'biological' or 'ecological' group. The evolutionary adaptations required for survival in the marine environment have led to convergence (similarity) in morphology.

Worldwide, there are about 12 major divisions, consisting of approximately 60 species (up to 72) of seagrass. The highest concentration of species occurs in the Indo-West Pacific region.

Over 30 species can be found within Australian waters. The most diverse seagrass communities are in the waters of north-eastern Queensland and southern Western Australia.

Various common names are applied to seagrass species, such as turtle grass, eelgrass, tape grass, spoon grass and shoal grass. Seagrasses are not seaweeds. Seaweed is the common name for algae.

### Seagrass requirements for growth

Seagrasses require light, nutrients, carbon dioxide, substrate for anchoring, tolerable salinity, temperature and pH to survive. The requirements for a seagrass to be able to exist in the marine environment include:

1. adaptation to life in saline (salty) medium
2. growth when completely submerged
3. anchoring system able to withstand the forces of wave action and tidal currents
4. hydrophilous pollination (pollination aided by water).

The need for physiological adaptations to life in sea water is obvious when one considers that seagrasses evolved from land plants, and most land plants are unable to tolerate even small quantities of salt. In contrast to land plants, some seagrasses can tolerate a salinity range from 4 to 65 parts per thousand (2x seawater concentration). Typically, seagrasses grow best in salinities of 35 parts per thousand. Not all species tolerate all salinities equally well, and salinity tolerance may be a factor promoting different species distributions along salinity gradients, e.g., going up estuaries. Some seagrasses can survive in a range of conditions encompassing fresh water, estuarine, marine, or hypersaline (very salty). A limiting factor for many intertidal seagrasses is osmotic impacts resulting from hypersalinity due to evaporation

Seagrasses being plants need light for photosynthesis. Light availability is the most dominant overriding factor in seagrass growth. Seagrasses have high minimum light requirements (e.g. 10-20% on average, 4.4% minimum and 29% maximum depending on species) of surface irradiance) because: (i) they have a high respiratory demand to support a large non-photosynthetic biomass (e.g. roots, rhizomes); (ii) they lack certain pigments and therefore can utilise only a restricted spectral range; and (iii) they must regularly oxygenate their root zone to compensate for anoxic sediment. However, light in the intertidal can be in excess of requirements and excess light can cause

Seagrass evolved 100 million years ago from land plants that returned to the sea

There are around 60 species of seagrass found in ocean throughout the world

Seagrasses need plenty of sun and clean water to grow.

Seagrasses are physiologically adapted to life in sea water

Seagrasses can tolerate a range of salinities. Some species are less tolerant than others

Light availability is the most important factor determining seagrass growth

Seagrasses require between 10-20% of surface light to grow

temporary photo damage. UV exposure can also have significant impacts on seagrasses.

Temperature influences the rate of growth and the health of plants, particularly at the extremes. As water temperatures increase (up to 38°C) the rate of photorespiration increases reducing the efficiency of photosynthesis at a given CO<sub>2</sub> concentration. The cause of thermal stress at higher temperatures (38°C to 42°C) is the disruption of electron transport activity via inactivation of the oxygen producing enzymes (proteins) of photosystem II. Above these temperatures many proteins are simply destroyed in most plants, resulting in plant death.

Temperature also controls the range of pH and dissolved carbon dioxide (CO<sub>2</sub>) concentrations in the water column; factors critical in plant survival in the marine environment.

Seagrasses require inorganic carbon for growth. They uptake inorganic carbon at the leaf surface via two pathways which are species-specific. Some species use bicarbonate (HCO<sub>3</sub><sup>-</sup>) as an inorganic carbon source (eg *Halophila ovalis*, *Cymodocea rotundata*, *Syringodium isoetifolium* and *Thalassia*), whereas others use enzymes to make CO<sub>2</sub> available as the inorganic carbon source (eg *Enhalus acoroides*, *Halodule*, *Cymodocea serrulata*).

Seagrasses require two key nutrients, nitrogen and phosphorous, for growth. In the coastal regions, seagrasses appear to be primarily limited by nitrogen and secondarily by phosphorus. The demand for nutrients by seagrasses appears to be seasonally dependent. During the growing season the demand for nutrients is high, however during the senescent season elevated nutrients may become toxic.

The availability of nutrients to seagrasses may also be dependent on sediment quality / geochemistry. Bioavailability of nutrients is dependent on particle size and type. For example, clay content influences sediment adsorptive capacity — the more clays the greater the absorptive capacity — and, calcium carbonate binds phosphorus, limiting its bioavailability.

Sediment quality, depth and mobility are important factors for seagrass composition, growth and persistence. Most seagrasses live in sand or mud substrates where their roots and rhizomes anchor the plants to the see floor. Some seagrasses such as *Cymodocea* spp. prefer deeper sediments while others can tolerate a broad range of sediment depths. Colonising seagrasses such as *Halophila* spp. and *Halodule uninervis* are better suited to mobile sediments than larger species. The biogeochemical characteristics of sediment that can affect the nutrient content/binding capacity, organic content and oxygen levels. Seagrasses are unable to grow in sediments of high organic content.

Currents and hydrodynamic processes affect almost all biological, geological and chemical processes in seagrass ecosystems at scales from the smallest (physiological and molecular) to the largest (meadow wide). The pollination of seagrass flowers depends on currents and without current flows, vegetative material and seeds will not be transported to new areas, and species will not be exchanged between meadows. Factors such as the photosynthetic rate of seagrasses depend on the thickness of the diffusive boundary layer that is determined by current flow, as is the sedimentation rate. Both influence growth rates of seagrass, survival of seagrass species and overall meadow morphology.

Water temperature influences the rate of growth and the health of seagrass

Seawater temperatures above 40°C will stress seagrass. Death occurs at temperatures above 43°C

Seagrass require inorganic carbon for growth

Seagrass uptake carbon via two different pathways

Seagrass require two key nutrients, nitrogen and phosphorous, for growth

Nutrient availability to seagrass is dependent on the type of sediment they grow in

Most seagrass live in sand or mud sediments

Sediment movement can determine the presence of seagrass species

Tidal currents are important for pollination and exchange of gases from the water to the plant

### Where are seagrasses found?

Seagrasses are found in ocean throughout the world. They occur in tropical (hot), temperate (cool) and the edge of the arctic (freezing) regions. Seagrass are mainly found in bays, estuaries and coastal waters from the mid-intertidal (shallow) region down to depths of 50 or 60 metres. Most species are found in clear shallow inshore areas [between mean sea-level and 25 metres depth](#).

Seagrasses survive in the intertidal zone especially in locations sheltered from wave action or where there is pooling of water at low tide, (e.g., reef platforms and tide pools), which protects seagrass from elevated temperatures and drying.

Seagrasses inhabit all types of ground (substrates), from mud to rock. The most extensive seagrass meadows occur on soft substrates like sand and mud.

The depth range of seagrass is most likely to be controlled at its deepest edge by the availability of light for photosynthesis. Exposure at low tide, wave action and associated turbidity and low salinity from fresh water inflow determines seagrass species survival at the shallow edge.

Seagrass plants form small patches that develop into large continuous meadows. These meadows may consist of one or many species: sometimes up to 12 species present within one location.

### How are seagrasses important to the marine ecosystem?

Seagrass communities are one of the most productive and dynamic ecosystems globally. Seagrasses may significantly influence the physical, chemical and biological environments in which they grow by acting as 'ecological engineers'. They provide habitats and nursery grounds for many marine animals and act as substrate stabilisers.

Seagrass meadows are highly productive. They have been documented to create habitat complexity compared with unvegetated areas, providing up to 27 times more habitable substrate, as well as providing refuge and food for a range of animals. About 40 times more animals occur in seagrass meadows than on bare sand.

One of the most important roles of seagrasses is providing a nursery and shelter area for fish and prawns which are valuable to fisheries. Juveniles of some important species which depend on seagrass meadows include fish such as perch, mullet, whiting, tailor, bream, snappers, emperors and sweetlips. Commercial penaeid prawns such as red spot king, brown tiger, grooved tiger and endeavour also live in seagrass meadows as juveniles. Tropical rock lobsters also live in seagrass meadows as juveniles. Shellfish such as some oysters and pearl shell may be more likely to settle and survive where there is seagrass. Juvenile and adult sandcrabs and flathead are just two species which spend most of their lives in seagrass meadows, where there is not only food but also protection from strong tidal currents and predators. Larger predatory animals such as herons, cormorants, sharks, barramundi, salmon, crocodiles, etc, are also attracted to the seagrass meadows by the schools of forage fish which seek shelter there.

Seagrass meadows are a major food source for a number of grazing animals and are considered very productive pastures of the sea. The dugong

Seagrass are commonly found in estuaries, shallow coastal locations, and on reef-tops.

Seagrass are mainly found in clear shallow inshore areas between mean sea-level and 25 metres depth.

The depth that seagrass are found underwater depends on the light availability (water clarity)

Seagrass plants form small patches that develop into large meadows

Seagrasses are important habitat and feeding grounds for marine organisms.

About 40 times more animals occur in seagrass meadows than on bare sand.

Seagrasses are important nursery grounds for fish, and they support many human commercial activities.



(*Dugong dugon*) and the green turtle (*Chelonia mydas*) mainly feed on seagrass. An adult green turtle eats about **two kilograms** of seagrass a day while an adult dugong eats about 28 to 40 kilograms a day. Both dugongs and turtles select seagrass species for food which are high nitrogen, high starch and low fibre. For example, the order of seagrass species preference for dugongs is *Halophila ovalis* > *Halodule uninervis* > *Zostera capricorni*. In sub-tropical and temperate areas, water birds such as black swans also eat seagrass.

Decomposing seagrasses provide food for benthic (bottom-dwelling) aquatic life. The decaying leaves are broken down by fungi and bacteria which in turn provide food for other microorganisms such as flagellates and plankton. Microorganisms provide food for the juveniles of many species of marine animals such as fish, crabs, prawns and molluscs.

The rhizomes and roots of the grasses bind sediments on the substrate, where nutrients are recycled by microorganisms back into the marine ecosystem. The leaves of the grasses slow water flow, allowing suspended material to settle on the bottom. This increases the amount of light reaching the seagrass meadow and creates a calm habitat for many species.

Seagrasses are nutrient sinks, buffering or filtering nutrient and chemical inputs to the marine environment. Seagrasses uptake nitrogen and phosphorus from coastal run-off that, in overabundance, can lead to algal blooms that can impair water quality.

#### Interactions with mangroves and coral reefs

Tropical seagrasses are important in their interactions with mangroves and coral reefs. All these systems exert a stabilizing effect on the environment, resulting in important physical and biological support for the other communities).

Barrier reefs protect coastlines, and the lagoon formed between the reef and the mainland is protected from waves, allowing mangrove and seagrass communities to develop. Seagrasses trap sediment and slow water movement, causing suspended sediment to fall out. This trapping of sediment benefits coral by reducing sediment loads in the water.

Mangroves trap sediment from the land, reducing the chance of seagrasses and corals being smothered. Sediment banks accumulated by seagrasses may eventually form substrate that can be colonized by mangroves. All three communities trap and hold nutrients from being dispersed and lost into the surrounding oceanic waters.

#### Valuation of seagrasses

The valuation of ecosystem services is a very controversial topic in today's literature. Ecosystem Services are the processes by which the environment produces resources that we often take for granted. For seagrasses it is services such as clean water, preventing erosion, and habitat for fisheries.

The economic values of seagrass meadows are very large, although not always easy to quantify. Seagrass meadows are rated the 3rd most valuable ecosystem globally (on a per hectare basis), only preceded by estuaries and wetlands. The average global value of seagrasses for their nutrient cycling services and the raw product they provide has been estimated at 1994 US\$ 19,004 ha<sup>-1</sup> yr<sup>-1</sup>.

Dugongs can eat up to 40kg of seagrass per day.

Dugongs and turtles select seagrass species for food which are high nitrogen, high starch and low fibre

Seagrasses also contribute to the productivity of ecosystems via the detrital food pathway

Seagrass binds sediments and help prevent erosion

Seagrasses slow water flow and increase water clarity

Seagrass help remove harmful nutrient and sediment pollution from coastal waters

Seagrasses, mangroves and coral reef interact, providing physical and biological support for other communities

Seagrass meadows are rated the 3rd most valuable ecosystem globally (more valuable than mangroves or coral reefs)

**What causes seagrass areas to change?**

Tropical seagrass meadows vary seasonally and between years, and the potential for widespread seagrass loss has been well documented.

Factors which affect the distribution of seagrass meadows are sunlight and nutrient levels, water depth, turbidity, salinity, temperature, current and wave action.

Seagrasses respond to natural variations in light availability, nutrient and trace element (iron) availability, grazing pressure, disease, weather patterns, and episodic floods and cyclones. The dynamic nature of seagrass meadows in response to natural environmental variation complicates the identification of changes caused by humans.

**What threatens seagrass?**

Seagrass meadows can be easily damaged. Approximately 58% of seagrass meadows globally, have lost part of their distribution. According to reports, the documented losses in seagrass meadows globally since 1980 are equivalent to two football fields per hour.

Some losses are natural due to storms and herbivores, however most losses are the result of human activities. Human pollution has contributed most to seagrass declines around the world.

The most widespread and pervasive cause of seagrass decline is a reduction in available light. Processes that reduce light penetration to seagrasses include pulsed turbidity events during floods, enhanced suspended sediment loads and elevated nutrient concentrations. Poor farming practices can result in excess sediments and fertilizers washing down creeks to the sea. Sewage discharge and stormwater runoff from urban development can elevate nutrients in coastal areas. Boating activity may also stir up sediment, reducing light levels. Phytoplankton and fast-growing macroalgae are also better competitors for light than benthic plants and their biomass can shade seagrasses during progressive eutrophication.

Oil and trace metal contamination can exert direct toxic effects on some seagrass species. Seagrasses are able to bioaccumulate the trace metals and this can have ramifications for grazers such as dugongs.

People can also physically damage or destroy seagrass. Coastal development for boat marinas, shipping ports and housing generally occurs on the coast in areas which are sheltered and seagrass like to grow. Seagrass meadows are either removed or buried by these activities. Coastal developments can also cause changes in water movement. Dredging boat channels to provide access to these developments not only physically removes plants, but can make the water muddy and dump sediment on seagrass. Litter and rubbish can also wash into the sea if not properly disposed. Rubbish can physically and chemically damage seagrass meadows and the animals that live within them.

Boating and fishing activities can physically impact or destroy seagrasses. Boat anchors and their chains can dig into seagrass. Propellers can cut into seagrass meadows and unbalance the rhizome mat. Storms can further exacerbate the damage by the physical force of waves and currents ripping up large sections of the rhizome mat. Uncontrolled digging for bait worm can also physically damage seagrasses and some introduced marine pests and pathogens also have the potential to damage seagrass meadows.

Seagrasses can change due to both natural and human impacts

People can damage or destroy seagrass by pollution (sewage, oil spills and coastal runoff) and physical destruction (dredging, bait & clam digging, boat propellers and anchors/moorings).

Poor farming practices can result in runoff which can damage seagrass by elevating nutrients, reducing available light and releasing herbicides.

Coastal development can have a major impact on seagrass meadows

One of the other significant impacts to seagrass is climate change. The major vulnerability of seagrass to climate change is loss of seagrass in the coastal zone, particularly near river mouths and in shallow areas. The greatest impact is expected to result from elevated temperatures, particularly in shallower habitats where seagrasses grow (e.g., effecting distribution and reproduction). In addition, reduced light penetration from sediment deposition and resuspension are expected due to more intensive cyclones/hurricanes and elevated flooding frequency and amplitude. This will result in even greater seagrass losses, and changes in species composition are expected to occur particularly in relation to disturbance and recolonisation. Following such events, a shift to more ephemeral species and those with lower minimum light requirements is expected.

Climate change can threaten intertidal seagrass by increased seawater temperature and greater physical disturbance from storms

**Please note:** citations have been removed for ease of reading. Please see *References & Further Reading* for source/citations on scientific facts.

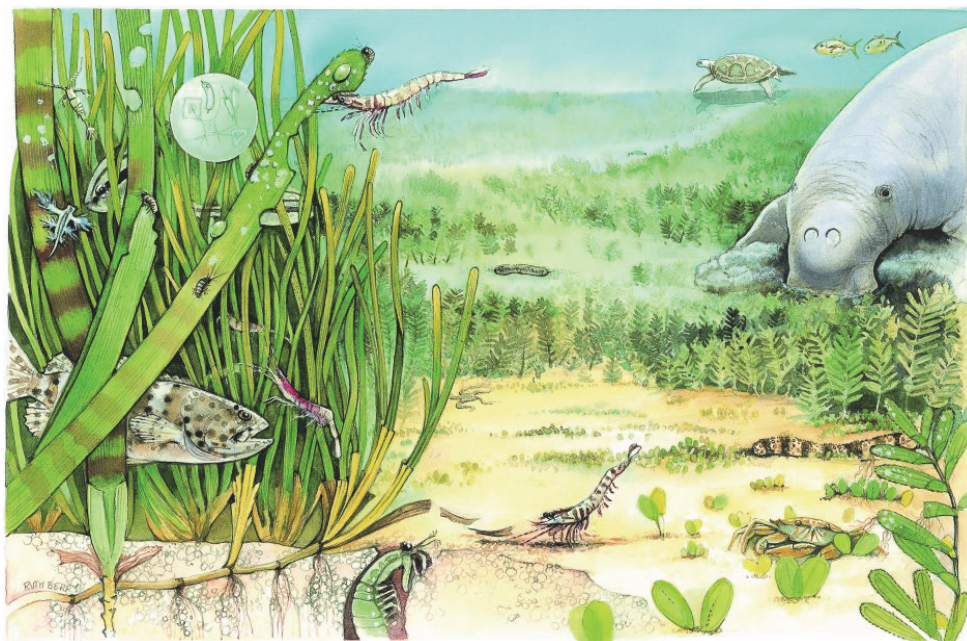

## Notes:

.....

.....

.....

.....

.....

.....

.....



## Interesting facts:

Over a billion people live within 50 km of a seagrass meadow. Millions of people obtain their protein from animals that live in seagrasses.

The estimated coverage of seagrasses globally is over 177,000 square kilometres.

A hectare of seagrass absorbs 1.2 kilograms of nutrients per year, equivalent to the treated effluent from 200 people.

In northern Australia, whole seagrass meadows are able to completely replace their leaves (turnover) in around 14 days during the growing season.

A hectare of seagrass sequesters 830 kilograms of carbon per year, equivalent to the CO<sub>2</sub> emissions from an automobile travelling 3,350 km.

One square metre of seagrass can produce up to 10 litres of oxygen per day

In northern Australia, the primary productivity of seagrass meadows is higher than a mangrove forest, a terrestrial forest or grassland.

Seagrasses occupy only 0.1% of the seafloor, yet are responsible for 12% of the organic carbon buried in the ocean, which helps reduce greenhouse gases.

The only endangered marine plant is a species of seagrass (*Halophila johnsonii* in Florida).

There is a single clone of seagrass that is over 6,000 years old (*Posidonia oceanica* in the Mediterranean Sea). It is possibly the world's oldest plant!

The deepest growing seagrass (*Halophila decipiens*), 86 metres, was reported from Cargados Carajos Shoals in the Indian Ocean northeast of Mauritius.

Seagrass produce the longest pollen grains on the planet.

Some intertidal species of seagrasses can lose up to 50% per cent of their water content and still survive.

Did you know that Australia has the highest number of seagrass species of any continent in the world?

In Alaska, seagrasses remain frozen and in a dormant state over winter and do not start to grow again until the thaw.

The longest known seagrass 7.3 metres in length has been reported from Funakoshi Bay, Japan.

40,000 seeds of *Halodule uninervis* have been found in 1 square metre of mudflat.

In Florida, 80% of the above ground seagrass biomass is consumed by parrot fish.

The anchor and chain from one cruise boat can destroy an area of seagrass the size of a football field!



# Seagrass in the Kimberley region of Western Australia

Updated from McKenzie (2007)

The Kimberley region of Western Australia extends from the border with the Northern Territory in the north to Sandy Point (Roebuck Bay) in the south. The marine ecosystems are characterised within the North-West Marine Bioregion (Anon 2008). Seagrasses are a significantly component in the coastal marine ecosystems and their contribution to the total primary carbon production is critical to regionally important dugong and turtle populations.

The Kimberley coast displays wide variation and is a significant component of the region's physical setting. It is a typical drowned river valley system, with wide sandy beaches which give way to mudflats. Embayments and sounds grade shorewards into mangrove lined tidal flats. Mangrove inlets and tidal creeks are interspersed with coastal cliffs. Some embayments such as Cambridge Gulf and King Sound extend well inland. There are numerous offshore islands and much of the coast remains uninhabited.

The Kimberley coast region of Western Australia has both arid and wet tropical environments (annual average rainfall <200 mm and >1000 mm respectively). The marine environment is influenced by the warm, south-equatorial current that flows from the east through the Asian and northern Australian region. The coast is prone to large tidal variation from <1 to 11m (Walker and Prince 1987). In King Sound, the highest tides reach 11m. Strong tidal flows, together with summer river discharges, dramatically influence the coastal environment.

Western Australia has the highest diversity of seagrasses in the world, with 25 species represented (Walker & Prince 1987; Kirkman 1997; Walker 2003). These are generally divided into temperate and tropical distributions, with Shark Bay representing the biogeographical overlap. 12 species are represented in the tropics (*Thalassia hemprichii*, *Thalassodendron ciliatum*, *Enhalus acoroides*, *Halophila ovalis*, *Halodule uninervis*, *Halophila minor* (revised from *H. ovata*<sup>1</sup>), *Cymodocea angustata*, *Syringodium isoetifolium*, *Cyrtodocea serrulata*, *Halophila spinulosa*, *Halodule pinifolia* and *Halophila decipiens*), one of which is endemic (*Cymodocea angustata*) (Kirkman 1997; Walker 2003)

Seagrass distribution throughout the region is most likely influenced by shelter, sediment characteristics, water turbidity and tidal exposure. Seagrass meadows are mostly found in the sheltered bays along the southern mainland coast. Extensive terracing of these expanses of the intertidal zone often result in seagrass high in the intertidal (Walker 2003). The majority of the meadows are low - moderate in abundance, and are dominated by *Halophila* and *Halodule* species. Seagrasses either occur sparsely in coral reef environments or can attain high biomasses on mudbanks or within high intertidal lagoons, where water is ponded during the falling tide. The environments are otherwise too extreme (tidal movement/turbidity/freshwater runoff in the wet season) for seagrass survival (Dennison & Kirkman 1996). Subtidal populations of seagrasses are poorly known, but it appears that the northern Kimberley does not have the seagrass richness recorded for the southern Kimberley.

---

<sup>1</sup> *Halophila minor* was originally reported as *H. ovata*, however taxonomists now regard *H. ovata* in the Indo-western Pacific as only present in the South China Sea and Micronesia (Kuo 2000).

## Roebuck Bay

Roebuck Bay is a tropical marine embayment with extensive, highly biologically diverse, intertidal mudflats. The Bay is bounded to the north-west by the township of Broome (population ca. 13,500 in 2006) and extends to Sandy Point in the south. Declared a Ramsar site, it is internationally important for at least 20 species of migratory shorebirds and one of the most important sites for shorebird conservation in the East Asian-Australasian Flyway in Australia and globally. Dugongs (*Dugong dugon*) and Green turtles (*Chelonia mydas*) regularly use the bay as a feeding area and as a transit area on migration. The Bay is also a major nursery area for marine fishes and crustaceans, and supports an exceptionally high biomass and diversity of benthic invertebrates (estimated to be between 300 – 500 species), placing it amongst the most diverse mudflats known in the world (de Goeij *et al.* 2003).

Roebuck Bay has a very large tidal range which exposes around 160 km<sup>2</sup> of mudflat, approximately 45% of the total bay area, with tides travelling at up to 20cm/sec mid cycle (Hickey *et al.* 1998; Piersma *et al.* 2002). Most of the mudflat area is inundated by each high tide and at times, spring tides and/or cyclones may cause the adjoining coastal flats to become inundated. The tidal system is semi-diurnal with an average tidal amplitude of 5.7m. Tidal range varies from c. 1 m on neap tides to 10.5 m on the highest spring tides. These factors dominate the intertidal ecology.

Extensive seagrass meadows occur in the northern regions of Roebuck Bay, particularly in the Town Beach area, and are dominated by *Halophila ovalis* and *Halodule uninervis* ([www.seagrasswatch.org](http://www.seagrasswatch.org)). The most vigorous stands of seagrass grow in areas that are exposed for less than two hours at low tide (Prince 1986). *Halophila minor* occurs sparsely by itself, often in pools which remain in the high intertidal during low tides, or with some *H. uninervis* (Prince 1986). *Halodule pinifolia* has also been reported from northern Roebuck Bay, but mixed with other species (Walker and Prince 1987).

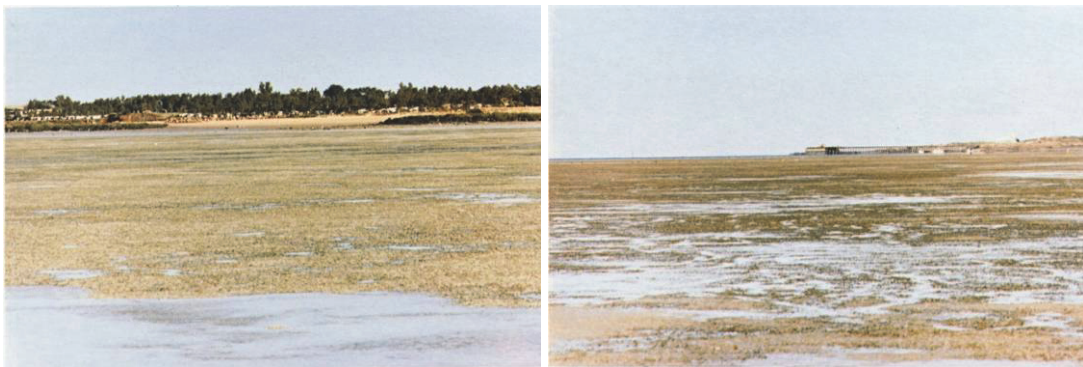

Mixed *Halophila ovalis* and *Halodule uninervis* meadow adjacent to Mangrove Point inner anchorage area, Roebuck Bay - 01 August 1984 (tide 0.3m). Photos: R Prince DCLM (from Prince 1986).



Mixed *Halophila ovalis* and *Halodule uninervis* meadow adjacent to Mangrove Point inner anchorage area, Roebuck Bay – September 2007 (L) & August 2009 (R) . Photos: Len McKenzie.



*Halophila ovalis* (above left) and *Halodule uninervis* (above right) meadow adjacent to Mangrove Point, Roebuck Bay - 01 August 1984. Photos: R Prince DCLM (from Prince 1986).



*Halophila ovalis* (above left) and *Halodule uninervis* (above right) meadow adjacent to Mangrove Point, Roebuck Bay - 7 November 2006. Photos: Danielle Bain EK.

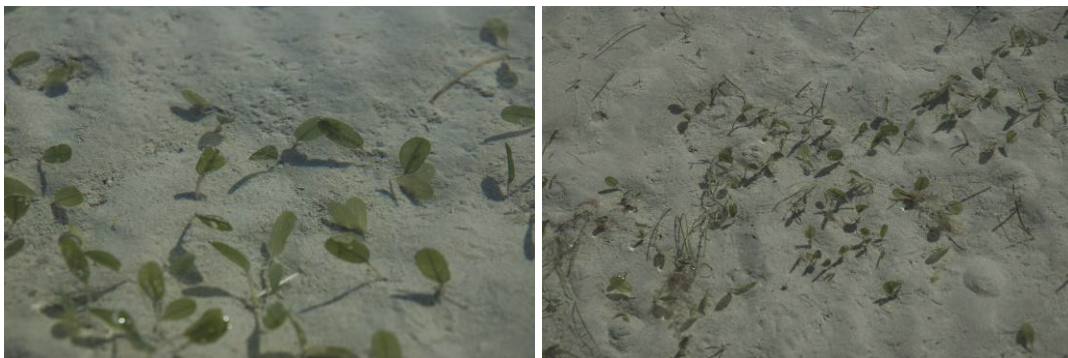

*Halophila ovalis* (above left) and *Halophila ovalis* / *Halodule uninervis* (above right) meadow at RO2, Roebuck Bay - 3 September 2007. Photos: Len McKenzie.



*Halophila minor* meadow on intertidal mud banks to north of Buccaneer Rock, Roebuck Bay - 31 July 1984. Photos: R Prince DCLM (from Prince 1986).

A survey of dugongs in the Kimberley, conducted by the Department of Conservation and Land Management in 1984 (Prince 1986), estimated the population in Roebuck Bay at 50 - 100 individuals. Current population levels are unknown.



Dugong feeding trails in mixed *Halophila ovalis* and *Halodule uninervis* meadow adjacent to Mangrove Point inner anchorage area, Roebuck Bay:

Left - 01 August 1984. Photo: R Prince DCLM (from Prince 1986), Middle & Right – December 2008. Photo: Fiona Bishop.

### **Cable Beach to Quondong Point**

North of Roebuck Bay, isolated *Halodule uninervis* patches have been reported at Barred Creek (Cape Boileau) and monospecific meadows of *Syringodium isoetifolium* at Quondong Point, in rock pools with coarse sediments (Prince 1986).

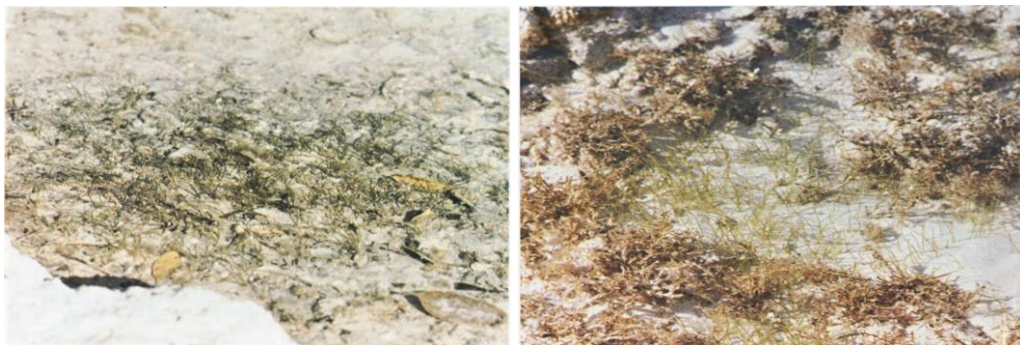

*Halodule uninervis* meadow (above left) in pool on raised terrace, Barred Creek (Cape Boileau - 28 July 1984) and *Syringodium isoetifolium* meadow( above right), Quondong Point (29 July 1984). Photo: R Prince DCLM (from Prince 1986).

### **Quondong Point to Coulomb Point**

The majority of the area around Coulomb Point consisted of fine sand substratum (70% sand coverage), from the shallow water out to the extent of the survey boundary, with patches of sand waves and dunes seen in the shallower water transects.

The presence of seagrass had been suggested in the subtidal areas adjacent to James Price Point due to the presence of dugongs (Prince 1986), however this was not verified until the area was examined between November 2007 and December 2008 as part of a benthic habitat survey to identify possible locations for a proposed common-user liquefied natural gas (LNG) hub precinct in the Kimberley region (Fry et al. 2008).

Seasonally-abundant subtidal *Halophila* communities and turf or mat green algae were identified on the inshore flat sandy patches between subtidal sand dunes and waves (Fry et al. 2008). These subtidal meadows were first observed during surveys undertaken by DEC in November 2007, when seagrass abundance was seasonally high. Repeat surveys of some locations where seagrass was found in November 2007 were undertaken in April 2008 but no seagrass was recorded. Seagrass had re-established in these areas by June 2008 and surveys by

DEC in December 2008 found prolific seed production in *Halophila* sp, suggesting that recruitment from seed may be a very important process for sustaining these seagrass Communities (Masini *et al.* 2009).

The offshore flat sandy areas from Quondong Point to Coulomb Point were found to have almost exclusively bioturbated habitat dominated by sand dunes and waves. No seagrass or other marine plants were observed in these habitats.

### **Coulomb Point to Beagle Bay**

A few isolated patches of *Enhalus acoroides* have been reported on the reef flat on the south side of West Island in the Lacepedes group, and *Halophila ovalis* has been observed off the reef edge in the channel (R Prince, Pers. Comm.).

*Halophila spinulosa* which is usually found in deeper water (to 45 m depth) has been reported in shallower water in areas of rapid tidal movement either in patches between larger species or as sparse populations at Tooker Point (Alligator Creek) and Sandy Point (Beagle Bay) (Walker and Prince 1987). Extensive *Halophila minor* meadows have also been reported to occur in the shallower waters at Tooker Point, Alligator Creek, and Sandy Point, Beagle Bay (Walker and Prince 1987). Dugongs feeding trails and animals have been observed in the area.

### **Beagle Bay to Cape Borda (including Perpendicular Head)**

Seagrass was reported in the inshore areas of Perpendicular Head during a benthic habitat survey to identify possible locations for a proposed common-user liquefied natural gas (LNG) hub precinct in the Kimberley region (Fry *et al.* 2008). Small isolated patches of unidentified *Halophila* species were observed throughout the area where flat sandy substrates dominated. Most of the inshore areas of Perpendicular Head were dominated by green turf or mat algae and patches of red algae.

No seagrass has been reported in the deeper waters of the region (15-20m) where the seabed is predominantly made up of fine sand (70% coverage) interspersed with small patches of sand waves and dunes (Fry *et al.* 2008).

### **Cape Borda to Cape Leveque**

The coastal seabed in this region is predominately low (< 0.5m) and high (0.5-2m) relief reef structure separated by patches of coarse sand, sand waves and dunes (Fry *et al.* 2008). Seagrass (unidentified *Halophila*) is present in relatively high coverage within the small bays in the northern part of this region in June 2008 (Fry *et al.* 2008). Green algae (turf and mat) are also common in the shallow and intertidal areas along the coast. Little biohabitat is present in offshore areas where the substrate was mostly fine sand and some coarse sand patches.

Located south of Cape Leveque, the Chile Creek seascape is significantly influenced by the high tidal range (9.6m). Dense patches of *Enhalus acoroides* with *Halophila ovalis* and *Halodule uninervis* are found scattered amongst the large tidal pools that remain during the low spring tides ([www.seagrasswatch.org](http://www.seagrasswatch.org)). This is one of the few locations in Western Australia where *Enhalus acoroides* has been found. Dugongs have been reported to visit these meadows over time.



*Enhalus acoroides* meadow (above left) and *Halophila ovalis* (above right), Chile Creek (31 August 2007).  
Photo: Len McKenzie.

### King Sound region

King Sound encompasses the Fitzroy River estuary and is the receiving basin for the Fitzroy River. This region is macro-tidal with low wave energy. There are extensive tidal flats subject to extreme variations in turbidity and tide fluctuations throughout the area. There are also numerous islands in the region. The northern reaches of the sound includes the Buccaneer Archipelago. The region is an important area for dugongs, which have been reported from One Arm Point in the King Sound since 1688 (Adam 2003; Marsh 1991).

The most diverse seagrass meadows in the Kimberley region have been reported on the reef platforms in the One Arm Point – Sunday Island area. The location with the highest biodiversity of seagrasses was around One Arm Point, where ten species were reported (*Thalassia hemprichii*, *Thalassodendron ciliatum*, *Enhalus acoroides*, *Halophila ovalis*, *Halodule uninervis*, *Halophila minor*, *Cymodocea serrulata*, *Cymodocea angustata*, *Syringodium isoetifolium* and *Halodule pinifolia*) (Walker and Prince 1987).

Meadows are dominated by *Thalassia hemprichii* with *Halophila ovalis*, *Halodule uninervis* and *Halophila minor*. *Cymodocea serrulata* occurs on a raised reef platform at Sunday Island (protected from wave action) as a continuous canopy, or with *Enhalus acoroides* and *Thalassodendron ciliatum* (Walker and Prince 1987).



*Thalassia hemprichii* meadow on reef platform. Above left: Sunday Island channel, 6 August 1984. Photo: R Prince DCLM (from Prince 1986). Above right: One Arm Creek, 1 September 2007. Photo: L McKenzie.





Mixed *Thalassia hemprichii* and *Halophila ovalis* meadow, a. One Arm Point – 4 August 1984; b. Sunday Island channel, southern end – 6 August 1984. Photos: R Prince DCLM (from Prince 1986).

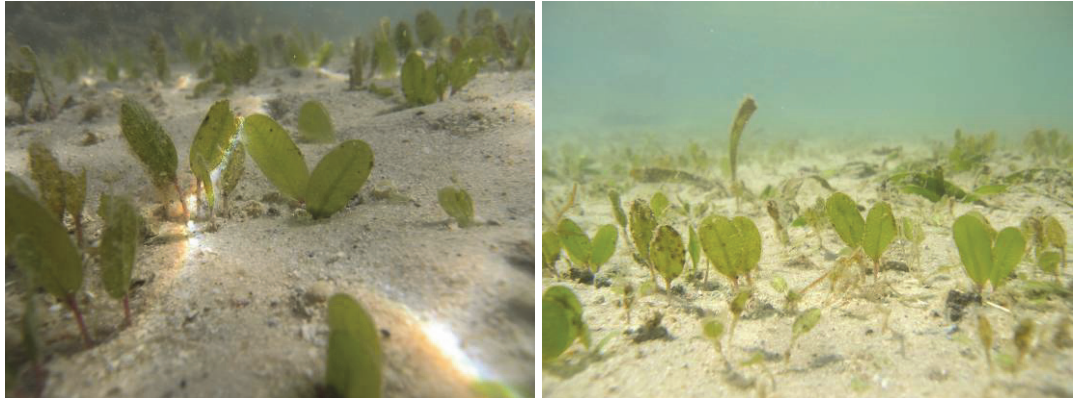

*Halophila ovalis* meadow on reef platform, One Arm Creek, 1 September 2007. Photo: L McKenzie.



*Thalassia hemprichii* meadow on reef platform, One Arm Creek, 1 September 2007. Photo: L McKenzie.

*Enhalus acoroides* is only known in Western Australia from the One Arm Point, Chile Creek and Lacepedes regions where it occurs in isolated patches in coarse sediments on raised reef platforms (Walker and Prince 1987).



*Enhalus acoroides* meadow, a. One Arm Point – 4 August 1984; b. Sunday Island, southern end – 6 August 1984. Photos: R Prince DCLM (from Prince 1986).



*Enhalus acoroides* isolated plants (left) and patches (right) on reef platform, One Arm Creek, 1 September 2007.  
Photo: L McKenzie.



Mixed *Thalassia hemprichii* and *Halodule uninervis* meadow, One Arm Point: left – 4 August 1984. Photo: R Prince DCLM  
(from Prince 1986). Right, 1 September 2007. Photo: L McKenzie.

These tropical seagrasses are relatively numerous around the Northern Islands of the Buccaneer Archipelago, however they do not form extensive meadows along the coast where the strong currents and large tidal flows are predominant.

It is unknown if the seagrasses of One Arm Point have changed significantly since the 1980's. In an attempt to provide a better understanding of the status of seagrass meadows and how they change seasonally, Seagrass-Watch monitoring sites are planned to be established in the region by the Kimberley Land Council - Land & Sea Unit in partnership with the Bardi Jawi people.

### **King Sound to NT border**

Unfortunately, little information is available on the estuarine and marine flora present or likely to occur in the northern Kimberley region, as the coastline is largely unexplored for seagrass distribution. With high tidal range, visibility is often poor, and conventional remote sensing techniques are of limited use for mapping. The abundance of crocodiles make the survey of estuarine and marine plants difficult and hazardous. There are a few isolated reports of subtidal seagrasses at Scott Reef, Montgomery Islands, and on reefs at Talbot Bay (R Prince, Pers. Comm.). However, the remaining coast is particularly rugged and dominated by high temperature and pulsed turbidity events due to the high rainfall December – March.

In an aerial survey of the region in 1984, no dugongs were sighted (Prince 1987) suggesting that the probability of significant seagrass meadows is low. Nevertheless, dugongs are reported to occur in Napier Broome Bay near Kalumburu in the far north of the region.

## SEAGRASS-WATCH IN THE KIMBERLEY REGION

To provide an early warning of change, long-term monitoring has been established in Roebuck Bay as part of the Seagrass-Watch, global seagrass assessment and monitoring program ([www.seagrasswatch.org](http://www.seagrasswatch.org); McKenzie *et al.* 2000). Establishing a network of monitoring sites in the Kimberley region provides valuable information on temporal trends in the health status of seagrass meadows in the region and provides a tool for decision-makers in adopting protective measures. It encourages local communities to become involved in seagrass management and protection. Working with both scientists and local stakeholders, this approach is designed to draw attention to the many local anthropogenic impacts on seagrass meadows which degrade coastal ecosystems and decrease their yield of natural resources.



Seagrass-Watch monitoring at Town Beach (Roebuck Bay):  
left - September 2007 (Photo: Len McKenzie) and right – August 2009 (Photo: Rudi Yoshida)

The following is a summary of the current status of Seagrass-Watch monitoring in the Kimberley region.

### Roebuck Bay

**Monitoring:** ongoing, *quarterly*

**Principal watchers:** Anthony Aris, Catherine Cochrane, Trudy Classens, Kandy Curran, Sharon Ferguson, Jason Fong, Jane Lawton, William Miller, Louise Mullin, Luke Puertollano, Anthony Richardson, Curtis Robinson, Jason Simmons, Kevin Smith, Darren Stevens, Corey Thorne, Sam Tonkin.

**Occasional and past watchers:** Fiona Bishop, Kirsten Pearce, Danielle Bain, Thomas Aaron, Ben Ansell, Catherine Bishop, Janine Bedros, Taro Bin Amat, Adrian Boyle, Emily Burke, Kenneth Callaghan, Bel Catchside, Josh Coates, Maurice Connor, Jenny Costigan, Teressa Coutts, Hannah Curran, Miranda Curran, Theo Dann, Miranda Dibdin, Emma Ellis, Naomi Findlay, Pat Foley, S. Fong, Janine Furtado, Fiona Galloway, Dwayne George, Kevin George, Kate Golson, Karen Gorman, Michelle Haage, Luke Halling, Chris Howe Ping, Jeanette Hunt, Querida Hutchinson, Lauren Hutton, Mizuyo Ichinohe, Patrick Kitcchner, Pat Lowe, Elizabeth Malone, Tim Malone, Jacqueline McKenzie, Sarah McMillan, Clare Morton, Grant Morton, Julia Noakes, Howard Pedersen, Martin Pritchard, Todd Quartermaine, Chris Sampi, John Sawyer, Lindsay Sawyer, Erica Shedley, Troy Sinclair, Brendan Smith, Michelle Smith, David Trudgen, Wendy Trudgen, Mark Warren, Julie Western, Rebeka Wilson, Seagrass-Watch HQ

**Location:** intertidal sand flat in the northern section of the bay between Town Beach and the port.

**Site code:** RO1, RO2, RO3

**Issues:** coastal development, vessel movement, stormwater and urban runoff

**RO1 position:** S 17.97671 E122.23855 (*heading 160 degrees*)

**RO2 position:** S17.98062 E122.23173 (*heading 150 degrees*)

**RO3 position:** S17.99672 E122.21418 (*heading 120 degrees*)

**Best tides:** <0.6m (*port Broome 62650*)

**Issues:** Urban runoff



**Comments:** Extensive seagrass meadows occur in the northern regions of Roebuck Bay, particularly in the Town Beach area, and are dominated by *Halophila ovalis* and *Halodule uninervis*. Most abundance sections are where pooling of water occurs at low tide.

Dugong feeding trails are common. A survey of dugongs in the Kimberley, conducted by the DEC in 1984 (Prince 1986), estimated the population in Roebuck Bay at 50 - 100 individuals. Current population levels are unknown.

**Status (Apr11):**

- seagrass abundance appears significantly higher in 2008 compared to 2007, with the exception of RO1 when the highest abundances reported in December 2007 since sampling established in 2007.
- Abundances in 2011 at RO1 and RO2 appear similar than previous years.
- Seagrass abundance at RO3 in 2011 significantly higher than 2009 & 2010.

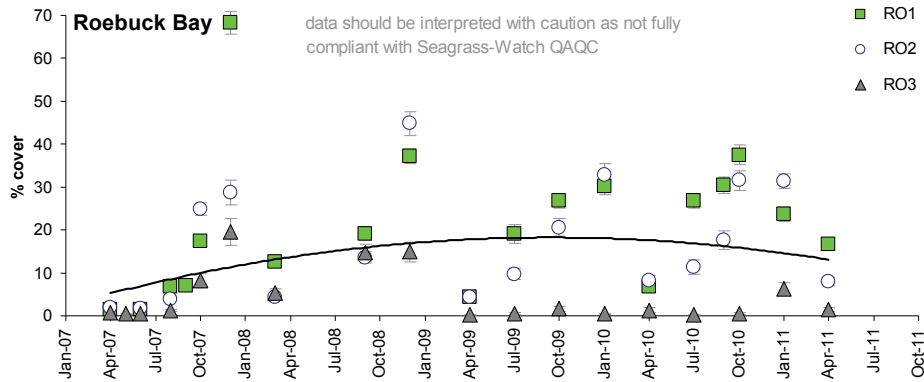

- all sites dominated by *Halodule uninervis* with variable composition of *Halophila ovalis*

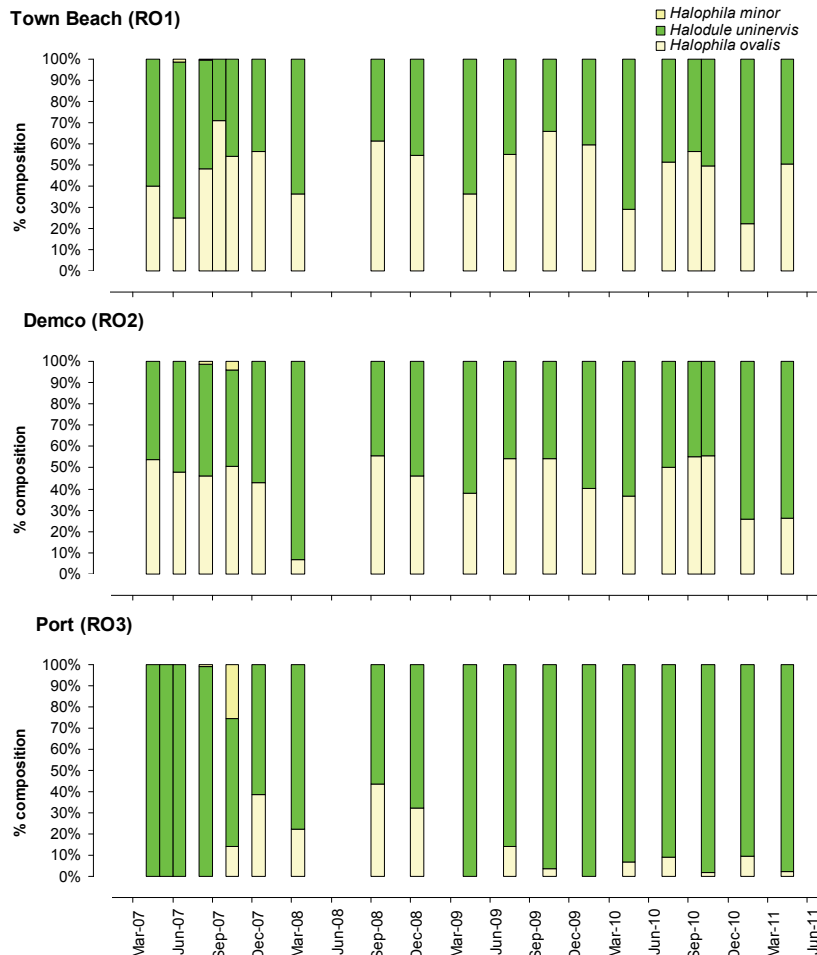

- seagrass abundance appears higher in late dry to early monsoon (October/December) and lower in late monsoon to early Dry (April/June).

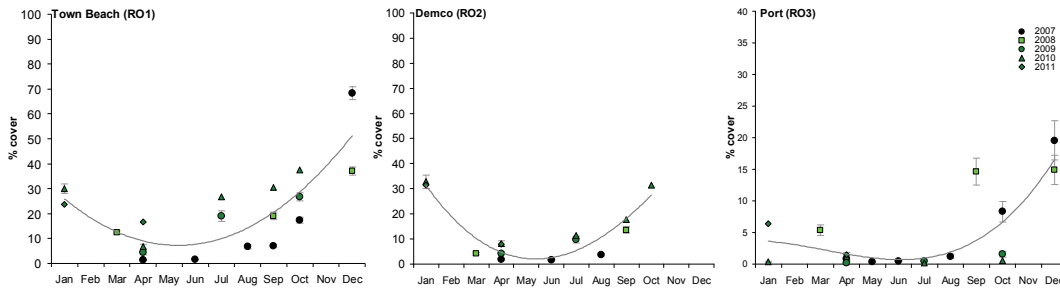

- insufficient sampling events to derive seagrass abundance indicators as variance for the 50th and 20th percentiles has not levelled off (*does not yet provide a reasonable estimate of the true percentile value*).
- using the seagrass guidelines values from Queensland (50<sup>th</sup> = 12.9; 20<sup>th</sup> = 6.6; Wet Tropics; similar latitude and species), seagrass state was determined for each monitoring event at each site
- for much of 2010/11, seagrass state was good at Town Beach (RO1) and Demco (RO2). Seagrass status remains poor at the Port (RO3) site.

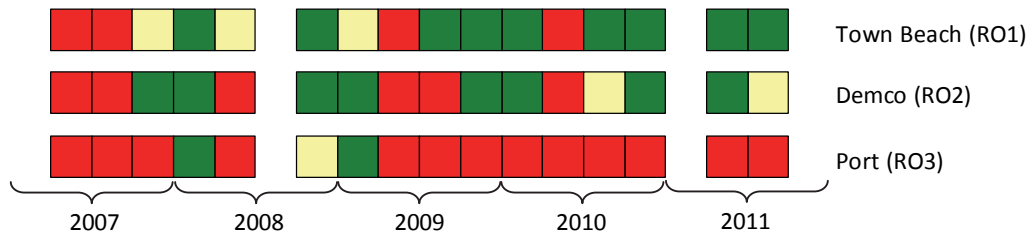

**Poor:** median seagrass abundance below lowest percentile (20<sup>th</sup> for variable and 10<sup>th</sup> for stable) for monitoring period.
  **Fair:** median seagrass abundance above lowest percentile (20<sup>th</sup> for variable and 10<sup>th</sup> for stable) but below 50<sup>th</sup> percentile for monitoring period.
  **Good:** median seagrass abundance above 50<sup>th</sup> percentile for monitoring period.

- Overall indications are that seagrass in the Broome region has remains in a **fair** state since monitoring began in 2007 (*state scored on a scale of 0 to 3 against the guidelines and relative to the previous sampling event*).

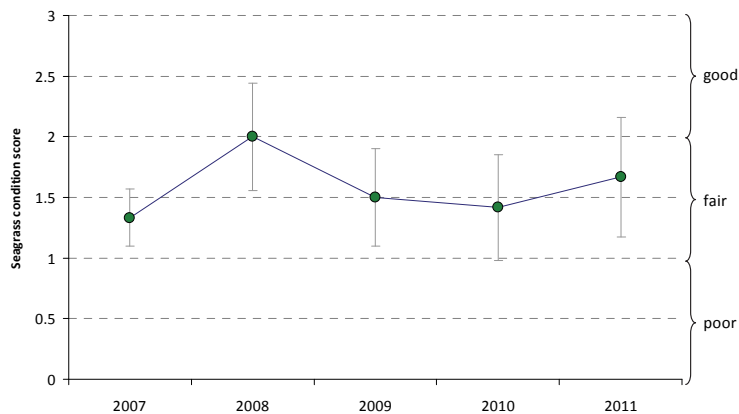

## Dampier Peninsula

**Monitoring:** ongoing, *quarterly*

**Principal watchers:** Todd Quartermaine, Trevor Sampi, Chris Sampi, Nathan Sampi, Kevin George, Dwayne George, Phillip McCarthy, Terry McCarthy, Mark Shadforth (Bardi Jawi Land and Sea Rangers)

**Location:** One Arm Point

**Site codes:** OA1

**OA1 position:** S16.43804 E123.06846 (*heading 30 degrees*)

**Chile Ck position:** S16.51832 E122.86389

**Best tides:** <4m Karakatta Bay (*port 62750*)

**Issues:** none identified

**Comments:** The most diverse seagrass meadows in the Kimberley region have been reported on the reef platforms in the One Arm Point. Dugongs and turtles are often reported feeding on these meadows.

It is unknown if the seagrasses of the Dampier Peninsula have changed significantly since the 1980's.

**Status (Aug11):**

- only 1 site established (no replication due to size of meadow)
- site only contains *Thalassia hemprichii*
- As there is insufficient data available, it is not possible to give an accurate assessment of the current status, but does not appear to be decline.

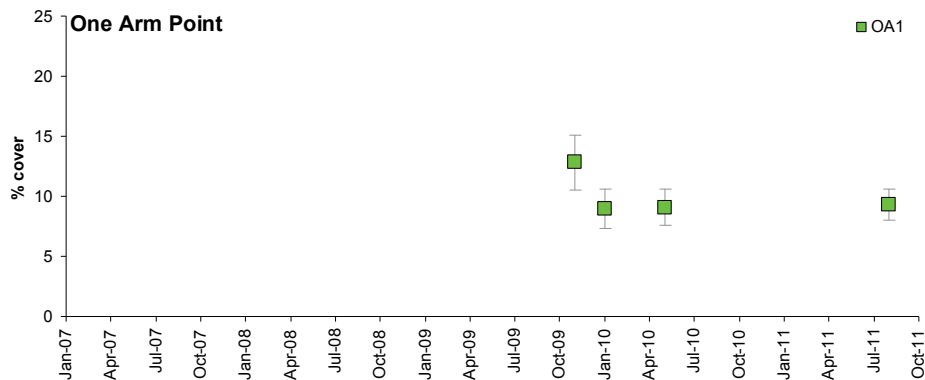

Seagrass-Watch monitoring, One Arm Point – May 2010 (L) & November 2009 (R). Photos Todd Quartermaine.

For more information, visit [www.seagrasswatch.org](http://www.seagrasswatch.org)

# A guide to the identification of tropical Western Australia's Seagrasses

Adapted from Waycott, M, McMahon, K, Mellors, J., Calladine, A., and Kleine, D (2004) A guide to tropical seagrasses in the Indo-West Pacific. (James Cook University Townsville) 72pp.

## Leaves cylindrical



cylindrical

### *Syringodium isoetifolium*

- leaves taper to a point
- leaves contain air cavities
- inflorescence a "cyme"
- leaves 7-30cm long

## Leaves oval to oblong



oval to oblong

### obvious vertical stem with more than 2 leaves

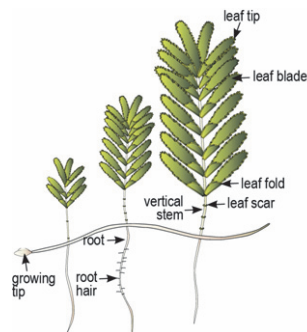

### *Halophila spinulosa*

- leaves arranged opposite in pairs
- leaf margin serrated
- shoots can be up to 15cm long
- 10-20 pairs of leaves per shoot
- leaf 15-20mm long and 3-5mm wide

### leaves with petioles, in pairs

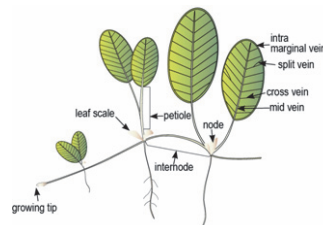

### *Halophila ovalis*

- cross veins more than 8 pairs
- leaf margins smooth
- no leaf hairs
- leaf 5-20mm long
- separate male & female plants

### *Halophila decipiens*

- leaf margins serrated
- 6-8 cross vein pairs
- fine hairs on both sides of leaf blade
- leaves are usually longer than wide

### *Halophila minor*

- leaf less than 5mm wide
- cross veins up to 8 pairs
- leaf margins smooth
- no leaf hairs

## Leaves strap-like

### Leaves can arise from vertical stem

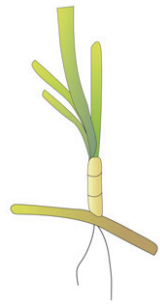

straplike

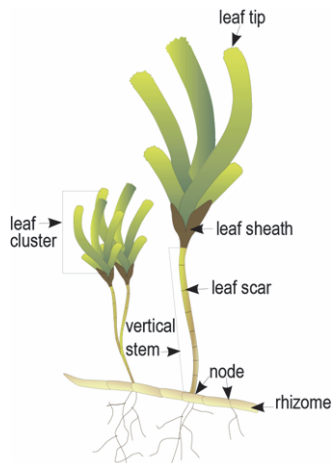

#### *Cymodocea angustata*

- Leaf tapers toward the apex, with widely spaced serration
- Leaf with <13 longitudinal veins
- Leaf sheath slightly obconical and scars open - not continuous around upright stem
- One unbranched root at each node on rhizome

#### *Cymodocea serrulata*

- leaf tip rounded with serrated edge
- leaf sheath broadly flat and triangular, not fibrous
- leaf sheath scars not continuous around upright stem

#### *Halodule pinifolia*

- leaf tip rounded
- leaf with 3 distinct parallel- veins, sheaths fibrous
- rhizome usually white with small black fibres at the nodes

#### *Halodule uninervis*

- leaf tip tri-dentate or pointed, not rounded
- leaf with 3 distinct parallel- veins, sheaths fibrous
- narrow leaf blades 0.25-5mm wide
- rhizome usually pale ivory, with small black fibres at the nodes

#### *Thalassia hemprichii*

- ribbon-like, curved leaves 10-40cm long
- short red/black bars of tannin cells, 1-2mm long, in leaf blade
- leaf tip rounded may be slightly serrated
- 10-17 longitudinal leaf veins
- thick rhizome (up to 5mm) with conspicuous scars

#### *Thalassodendron ciliatum*

- distinct upright stem
- clusters of curved leaves (>5 mm wide), margins serrated
- stem and rhizome woody
- seedling germinates while attached to female plant

### Leaves always arise directly from rhizome

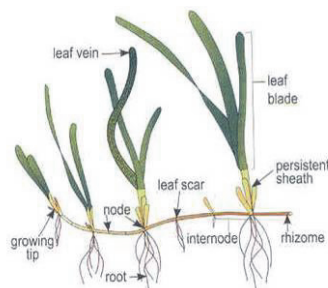

#### *Enhalus acoroides*

- large plant, leaves >30 cm long, >1 cm wide
- in-rolled edges of leaves
- long, black bristles protruding from thick rhizome
- cord-like roots



# Parts of a seagrass plant

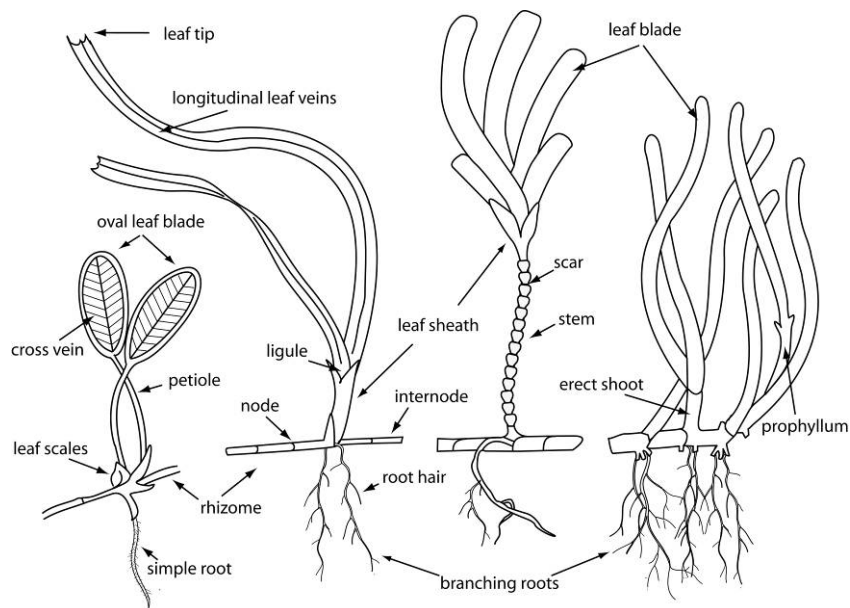

## Leaf

**Tip** Can be rounded or pointed. Tips are easily damaged or cropped, so young leaves are best to observe.



**Veins** Used by the plant to transport water, nutrients and photosynthetic products. The pattern, direction and placement of veins in the leaf blade are used for identification.

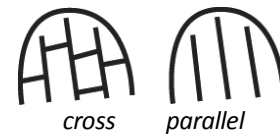

- cross-vein: perpendicular to the length of the leaf
- parallel-vein: along the length of the leaf
- mid-vein: prominent central vein
- Intramarginal-vein: around inside edge of leaf

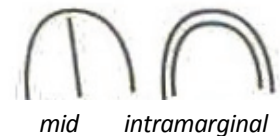

**Edges** The edges of the leaf can be either serrated, smooth or inrolled



**Sheath** A modification of the leaf base that protects the newly developing tissue. The sheath can entirely circle the vertical stem or rhizome (continuous) or not (non-continuous); fully or partly cover the developing leaves and be flattened or rounded. Once the leaf has died, persistent sheaths may remain as fibres or bristles.

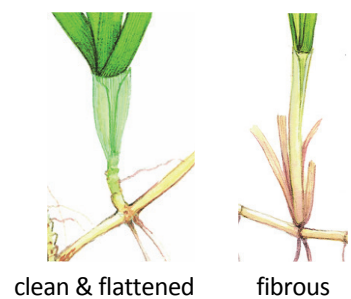

**Attachment** The leaf can attach directly to the rhizome, where the base of the leaf clasps the rhizome, or from a vertical stem or stalk (petiole) e.g. *Halophila ovalis*.

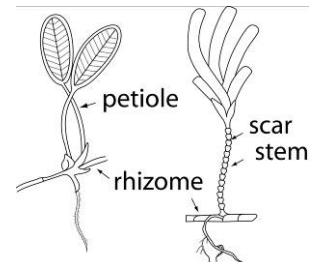

**Stem**

The vertical stem, found in some species, is the upright axis of the plant from which leaves arise (attach). The remnants of leaf attachment are seen as scars. Scars can be closed (*entirely circle the vertical stem*) or open (*do not entirely circle the vertical stem*).

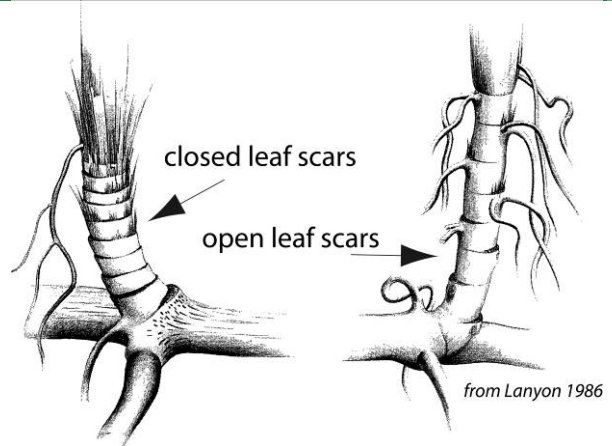

**Rhizome**

The horizontal axis of the seagrass plant, usually in sediment. It is formed in segments, with leaves or vertical stem arising from the joins of the segments, the nodes. Sections between the nodes are called internodes. Rhizomes can be fragile, thick and starchy or feel almost woody and may have scars where leaves were attached.

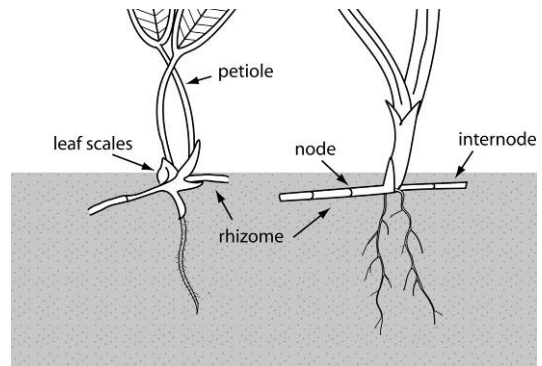

**Root**

Underground tissues that grow from the node, important for nutrient uptake and stabilisation of plants. The size and thickness of roots and presence of root hairs (very fine projections) are used for identification. Some roots are simple or cordlike, others may be branching, depending on seagrass species.

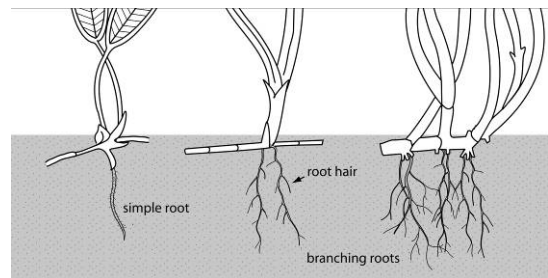

**Notes:**

.....

.....

.....

.....

.....

# Monitoring a seagrass meadow

Monitoring is the repeated observation of a system, usually to detect change. It is an integrated activity to evaluate the condition of the physical, chemical and biological character of the environment. Environment monitoring programs provide coastal managers with information and assist them to make decisions with greater confidence.

Environmental monitoring programs are ideally designed to: quantify the causes of change; examine and assess acceptable ranges of change for the particular site; and to measure levels of impacts.

Common drivers (reasons) for monitoring include: community interest; government policies such as Coastal Strategies and Plans, Oceans Policy, State of the Environment Reporting (SoE), Water Quality guidelines or Best Practice Guidelines; and Government Legislation (e.g., Fish Habitat Protection).

Users of the monitoring program information/results are diverse, including for example: the general public, environmental regulators - legislators, resource managers and scientists.

There are a number of issues to consider when implementing a monitoring program, including: ensure the protocols used have explicit objectives; clearly identified responsibilities of the partners (eg. Gov agencies, consultants, community groups); a clear and defensible rationale for using the parameters that are measures (eg physico/chemico, biological indicators); to have a [baseline \(first\) assessment / measure against which subsequent changes can be measured/compared](#); knowledge of spatial and temporal variation prior to designing the program (ie pilot study); clearly defined field protocols; data management procedures, ensure the level of change and accuracy of the detection is appropriate (as will vary according to the methodology); selection of statistical tools; and a mechanism to [reduce and manage errors \(ie QA/QC program\)](#).

Appropriate Quality Assurance/Quality Control (QA/QC) procedures are an integral component of all aspects of sample collection and analysis in monitoring programs. This includes participation in relevant inter-laboratory studies, proficiency testing, and the use of standard reference materials. Monitoring programs often include the following guidelines for implementation by data collectors and reporters:

- appropriate methods must be in place to ensure consistency in field procedures to produce robust, repeatable and comparable results including consideration of sampling locations, replication and frequency;
- all methods used must be fit for purpose and suited to a range of conditions;
- appropriate accreditation of participating laboratories or provision of standard laboratory protocols to demonstrate that appropriate laboratory QA/QC procedures are in place for sample handling and analysis;
- participation in inter-laboratory performance testing trials and regular exchange of replicate samples between laboratories;
- rigorous procedures to ensure 'chain of custody' and tracking of samples;
- appropriate standards and procedures for data management and storage; and
- a process to ensure data collectors are aware of any errors and provide an opportunity to clarify or correct data.

## Monitoring seagrass

Seagrasses are often at the downstream end of catchments, receiving runoff from a range of agricultural, urban and industrial land-uses. Seagrass communities are generally susceptible to changes in water quality and environmental quality that make them a useful indicator of environmental health. Seagrass make good **bioindicators** of environmental health because they are:

- are widely distributed;
- have an important ecological role;
- are sessile plants which show measurable and timely responses to external stressors/impacts (rather than relocating to a less stressful environment) and;
- are integrative of environmental conditions.

Several factors are important for the persistence of healthy seagrass meadows, these include: sediment quality and depth; water quality (temperature, salinity, clarity); current and hydrodynamic processes; and species interactions (e.g., epiphytes and grazers). Seagrass generally respond in a typical manner that allows them to be measured and monitored. In reporting on the health of seagrasses it is important to consider the type of factors that can effect growth and survival. Factors include:

- increased turbidity reduces light penetration through the water, interfering with photosynthesis and limiting the depth range of seagrass;
- increased nutrient loads encourages algal blooms and epiphytic algae to grow to a point where it smothers or shade seagrasses, thereby reducing photosynthetic capacity;
- increased sedimentation can smother seagrass or interferes with photosynthesis;
- herbicides can kill seagrass and some chemicals (e.g., pesticides) can kill associated macrofauna;
- boating activity (propellers, mooring, anchors) can physically damage seagrass meadows, from shredding leaves to complete removal;
- storms, floods and wave action can rip out patches of seagrasses.

## Seagrass-Watch

A simple method for monitoring seagrass resources is used in the Seagrass-Watch program. This method uses standardised measurements taken from sites established within representative intertidal meadows to monitor seagrass condition. The number and position of sites can be used to investigate natural and anthropogenic impacts.

Seagrass-Watch is one of the largest seagrass monitoring programs in the world. Since it's genesis in March 1998 in Australia, Seagrass-Watch has now expanded internationally to more than 26 countries. Monitoring is currently occurring at over 300 sites. To learn more about the program, visit [www.seagrasswatch.org](http://www.seagrasswatch.org).

Seagrass-Watch aims to raise awareness on the condition and trend of nearshore seagrass ecosystems and provide an early warning of major coastal environment changes. Participants of Seagrass-Watch are generally volunteers from a wide variety of backgrounds who all share the common interest in marine conservation. Most participants are associated with established local community groups, schools, universities & research institutions, government (local & state) or non-government organisations.

Seagrass-Watch integrates with existing education, government, non-government and scientific programs to raise community awareness to protect this important marine habitat for the benefit of the community. The program has a strong scientific underpinning with an

emphasis on consistent data collection, recording and reporting. Seagrass-Watch identifies areas important for seagrass species diversity and conservation and the information collected is used to assist the management of coastal environments and to prevent significant areas and species being lost.

Seagrass-Watch methods were developed to be rigorous, yet relatively simple and easy to use. Each of the parameters used have been carefully chosen with a clear and defensible rationale. The protocols used have explicit objectives and the sampling strategy is prepared using baseline and knowledge of spatial and temporal variation. As the collection of data by a diversity of participants necessitates a high level of training to ensure that the data is of a standard that can be used by management agencies. After 6–9 hours of training, participants can produce reliable data. Training includes both formal and informal approaches. Formal training is conducted by Seagrass-Watch HQ for participants over 17 years of age and includes formal lectures and on-site assessments with a tiered level of certification for competency. Formally trained participants are certified to supervise on-site monitoring and demonstrate (ie informally train) monitoring methods. Informal training is also conducted by local coordinators and/or scientists. Ideally, at least one formally trained volunteer is present at each monitoring event. Evidence of competency is securely filed at Seagrass-Watch HQ.

Seagrass-Watch has an accepted Quality Assurance-Quality Control program in place to ensure that the program is producing data of high quality, and that time and resources are not wasted. Seagrass-Watch HQ has systems in place to manage the way Seagrass-Watch data is collected, organised, documented, evaluated and secured. The Seagrass-Watch program collects and collates all data in a standard format. By using simple and easy methods, Seagrass Watch ensures completeness (the comparison between the amounts of valid or useable data originally planned to collect, versus how much was collected). Standard seagrass cover **calibration sheets** are used to ensure precision (the degree of agreement among repeated measurements of the same characteristic at the same place and the same time) and consistency between observers and across sites at monitoring times to [ensure percentage covers are close to a true or standardised value](#).

Other QAQC procedures include the selection of intertidal seagrass sites which are **permanently marked** with either plastic star pickets or an accurate ( $\pm 3$ m) GPS waypoint. Labels identifying the sites and contact details for the program are attached to these pickets. Positions of 0 m and 50 m points for all three transects at a site are also noted using GPS. This ensures that the same site is monitored each event and that [data can be compared between periods of time](#).

Ongoing standardisation of observers is achieved by on-site refreshers of standard percentage covers by all observers prior to monitoring and through ad hoc comparisons of data returned from duplicate surveys (e.g. either a site or a transect will be repeated by scientist – preferably the next day and unknown to volunteers). Any discrepancy in these duplicates is used to identify and subsequently mitigate bias. For the most part however uncertainties in percentage cover or species identification are mitigated in the field via direct communication (as at least one experienced/certified observer is always present), or the collection of voucher specimens (to be checked under microscope and pressed in herbarium) and the use of a digital camera to record images (protocol requires at least 27% of quadrats are photographed) for later identification and discussion.

Seagrass-Watch HQ has implemented a quality assurance management system to ensure that data collected is organised and stored and able to be used easily. All data (datasheets and photographs) received are entered onto a relational database on a secure server. Receipt of all original data hardcopies is documented and filed within the Queensland Government Registered Management System, a formally organised and secure system. Seagrass-Watch HQ operates as custodian of data collected from other participants and provides an evaluation and

analysis of the data for reporting purposes. Access to the IT system and databases is restricted to only authorised personnel. Provision of data to a third party is only on consent of the data owner/principal.

Seagrass-Watch HQ checks all data for completeness, consistency and accuracy. All data submitted to Seagrass-Watch HQ is first checked from compliancy:

- *legible original datasheets,*
- *good quality quadrat photographs (high resolution),*
- *voucher specimens (if required) and*
- *completed MS Excel spreadsheet.*

Validation is provided by checking observations against photographic records to ensure consistency of observers and by identification of voucher specimens submitted. In accordance with QA/QC protocols, Seagrass-Watch HQ advises observers via an official **Data Error Notification** of any errors encountered/identified and provides an opportunity for correction/clarification (this may include additional training).

Once Seagrass-Watch HQ has completed all checks, a field in the Master database identifies data as either passed, quarantined, non-compliant or not-passed. Non-compliant data is used for large-scale summary reporting only if the data quality is deemed acceptable, i.e. if it was collected by a Level 1 trained participant, that the scans/copies of datasheets are OK (*only if originals are not available*), and/or that the quadrat images were acceptable to complete QAQC, etc. If data quality is unacceptable, the data is either not entered into the Master database or remains quarantined/not-passed (excluded from analysis & reporting). If predominantly non-compliant data is used for detailed analysis and reporting at a site or location/region, it is marked on the outputs with a notice of non-compliance (e.g., site graphs). If officially requested data is non-compliant, a note in the metadata advises of non-compliance and includes a caveat to "use with caution". Any data considered unsuitable (e.g. nil response to data notification within thirty days) is quarantined or removed from the database.

Seagrass-Watch employs a proactive approach to monitoring, involving ongoing training for participants and the continued development of new methods and refinement of existing methods, including location/habitat specific calibration sheets, operation & validation of autonomous temperature and light loggers, etc. Quality data reassures the data users (e.g., coastal management agencies) that they can use the data to make informed decisions with confidence.

Seagrass-Watch monitoring efforts are vital to assist with tracking global patterns in seagrass health, and assessing human impacts on seagrass meadows, which have the potential to destroy or degrade these coastal ecosystems and decrease their value as a natural resource. Responsive management based on adequate information will help to prevent any further significant areas and species being lost. To protect the valuable seagrass meadows along our coasts, the community, government and researchers have to work together.

#### THE GOALS OF THE PROGRAM ARE:

- *To educate the wider community on the importance of seagrass resources*
- *To raise awareness of coastal management issues*
- *To build the capacity of local stakeholders in the use of standardised scientific methodologies*
- *To conduct long-term monitoring of seagrass & coastal habitat condition*
- *To provide an early warning system of coastal environment changes for management*
- *To support conservation measures which ensure the long-term resilience of seagrass ecosystems.*

# Seagrass-Watch Protocols

Source: McKenzie, L.J., Campbell, S.J., Vidler, K.E. & Mellors, J.E. (2007) *Seagrass-Watch: Manual for Mapping & Monitoring Seagrass Resources*. (Seagrass-Watch HQ, Cairns) 114pp ([www.seagrasswatch.org/manuals.html](http://www.seagrasswatch.org/manuals.html))

## Site layout

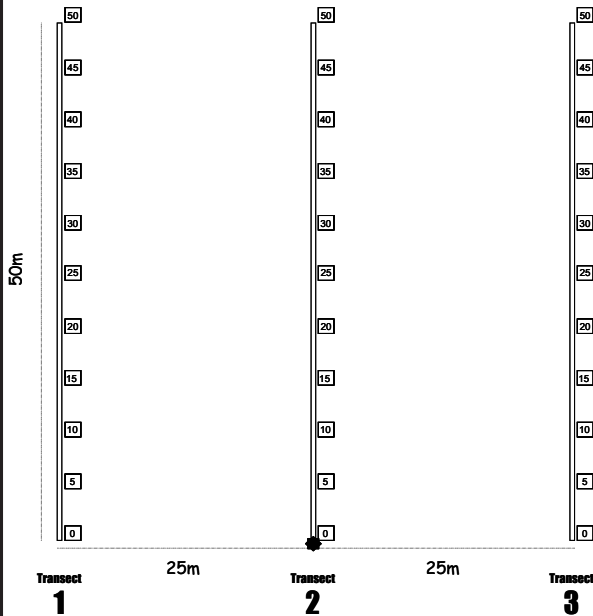

**Quadrat code = site + transect+quadrat**

**e.g., P11225 = Pigeon Is. site 1, transect 2, 25m quadrat**

## Pre-monitoring preparation

### Make a Timetable

Create a timetable of times of departure and arrival back, and what the objective of the day is and what is to be achieved on the day. Give a copy of this to all volunteers involved in advance so they can make their arrangements to get to the site on time. List on this timetable what the volunteers need to bring.

### Have a Contact Person

Arrange to have a reliable contact person to raise the alert if you and the team are not back at a specified or reasonable time.

## Safety

- Assess the risks before monitoring - check weather, tides, time of day, etc.
- Use your instincts - if you do not feel safe then abandon sampling.
- Do not put yourself or others at risk.
- Wear appropriate clothing and footwear.
- Be sun-smart.
- Adult supervision is required if children are involved
- Be aware of dangerous marine animals.
- Have a first aid kit on site or nearby
- Take a mobile phone or marine radio

## Necessary equipment and materials

- 3x 50metre fibreglass measuring tapes
- 6x 50cm plastic tent pegs
- Compass
- 1x standard (50cm x 50cm) quadrat
- Magnifying glass
- 3x Monitoring datasheets
- Clipboard, pencils & 30 cm ruler
- Camera & film
- Quadrat photo labeller
- Percent cover standard sheet
- Seagrass identification sheets

## Quarterly sampling

Within the 50m by 50m site, lay out the three 50 transects parallel to each other, 25m apart and perpendicular to shore (see site layout). Within each of the quadrats placed for sampling, complete the following steps:

### Step 1. Take a Photograph of the quadrat

- Photographs are usually taken at the 5m, 25m and 45m quadrats along each transect, or of quadrats of particular interest. First place the photo quadrat labeller beside the quadrat and tape measure with the correct code on it.
- Take the photograph from an angle as **vertical** as possible, which includes the entire quadrat frame, quadrat label and tape measure. Avoid having any shadows or patches of reflection off any water in the field of view. Check the photo taken box on datasheet for quadrat.

### Step 2. Describe sediment composition

- Dig your fingers into the top centimetre of the substrate and feel the texture. Describe the sediment by noting the grain size in order of dominance (e.g., Sand, Fine sand, Fine sand/Mud).

### Step 3. Describe other features and ID/count of macrofauna

- Note and count any other features which may be of interest (eg. number of shellfish, sea cucumbers, sea urchins, evidence of turtle feeding) within the comments column.

#### **Step 4. Estimate seagrass percent cover**

- Estimate the total % cover of seagrass within the quadrat – use the percent cover photo standards (calibration sheets) as your guide.

#### **Step 5. Estimate seagrass species composition**

- Identify the species of seagrass within the quadrat and determine the percent contribution of each species (starting with least abundant). Use seagrass species identification keys provided.

#### **Step 6. Measure canopy height**

- Measure canopy height (in centimetres) of the dominant strap-leaf seagrass species, ignoring the tallest 20% of leaves. Measure from the sediment to the leaf tip of at least 3 shoots.

#### **Step 7. Estimate algae percent cover**

- Estimate % cover of algae in the quadrat. Algae are seaweeds that may cover or overlie the seagrass blades. Use “Algal percentage cover photo guide”. Write within the comments section whether the algae is overlying the seagrass or is rooted within the quadrat.

#### **Step 8. Estimate epiphyte percent cover**

- Epiphytes are algae attached to seagrass blades and often give the blade a furry appearance. First estimate how much of the blade surface is covered, and then how many of the blades in the quadrat are covered (e.g., if 20% of the blades are each 50% covered by epiphytes, then quadrat epiphyte cover is 10%).
- Epifauna are sessile animals attached to seagrass blades – please record % cover in the comments or an unused/blank column – do not add to epiphyte cover.

#### **Step 9. Take a voucher seagrass specimen if required**

- Seagrass samples should be placed inside a labelled plastic bag with seawater and a waterproof label. Select a representative specimen of the species and ensure that you have all the plant part including the rhizomes and roots. Collect plants with fruits and flowers structures if possible.

### **At completion of monitoring**

#### **Step 1. Check data sheets are filled in fully.**

- Ensure that your name, the date and site/quadrat details are clearly recorded on the datasheet. Also record the names of other observers and the start and finish times.

#### **Step 2. Remove equipment from site**

- Remove all tent pegs and roll up the tape measures. If the tape measures are covered in sand or mud, roll them back up in water.

#### **Step 3. Wash & pack gear**

- Rinse all tapes, pegs and quadrats with freshwater and let them dry.
- Review supplies for next quarterly sampling and request new materials
- Store gear for next quarterly sampling

#### **Step 4. Press any voucher seagrass specimens if collected**

- The voucher specimen should be pressed as soon as possible after collection. Do not refrigerate longer than 2 days, press the sample as soon as possible.
- Allow to dry in a dry/warm/dark place for a minimum of two weeks. For best results, replace the newspaper after 2-3 days.

#### **Step 5. Submit all data**

- Data can be entered into the MS-Excel file downloadable from [www.seagrasswatch.org](http://www.seagrasswatch.org). Email completed files to [hq@seagrasswatch.org](mailto:hq@seagrasswatch.org)
- Mail original datasheets, photos and herbarium sheets

Seagrass-Watch HQ  
Northern Fisheries Centre  
PO Box 5396  
Cairns QLD 4870 AUSTRALIA



### *Enhalus acoroides*



- very long ribbon-like leaves with inrolled leaf margins
- thick rhizome with long black bristles and cord-like roots
- leaves >30cm long

### *Halophila ovalis*

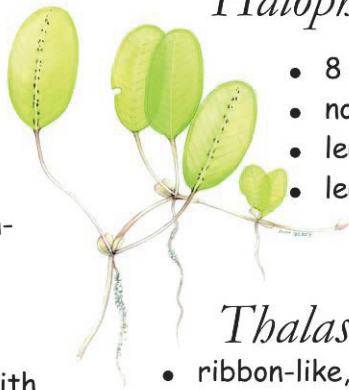

- 8 or more cross veins
- no hairs on leaf surface
- leaf margins smooth
- leaf 5-20mm long

### *Thalassia hemprichii*



- ribbon-like, curved leaves 10-40cm long
- leaf tip rounded, slightly serrated
- short black tannin cells, 1-2mm long, in leaf blade
- thick rhizome with scars between shoots

### *Halodule uninervis*



- trident leaf tip
- 1 central vein
- usually pale rhizome, with clean black leaf scars

### *Halodule pinifolia*



- rounded leaf tip
- 1 central vein
- usually pale rhizome, with clean black leaf scars

### *Cymodocea angustata*

- leaf tapers toward tip, widely spaced serrations
- leaf with <13 longitudinal veins
- leaf sheath slightly obconical and scars open
- one unbranched root at each

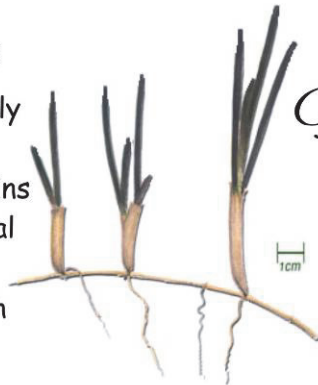

### *Cymodocea serrulata*

- serrated leaf tip
- wide leaf blade (5-9mm)
- leaves 6-15cm long
- 13-17 longitudinal veins
- clean triangular sheath
- robust/strong rhizome

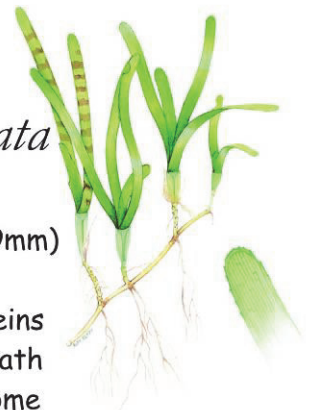

### *Syringodium isoetifolium*



- narrow spaghetti-like leaves
- cylindrical in cross section, 1-2mm diameter
- leaves contain air cavities
- leaf tip tapers to a point
- leaves 7-30cm long

### *Halophila minor*

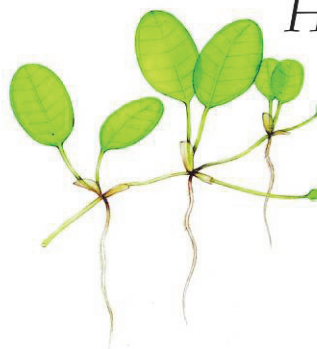

- less than 8 pairs of cross veins
- small oval leaf blade less than 5mm wide
- leaf margins smooth
- no leaf hairs



# SEAGRASS-WATCH MONITORING



ONE OF THESE SHEETS IS TO BE FILLED OUT FOR EACH TRANSECT YOU SURVEY

START of transect (GPS reading)

Latitude:  $25^{\circ} 11.2878$ , S Longitude:  $152^{\circ} 37.5372$ , E

OBSERVER: Dev Citizen DATE: 17/2/09  
 LOCATION: Burnum Heads  
 SITE code: BH1 TRANSECT no.: 2  
 START TIME: 1304 END TIME: 1340

Quadrat (metres from transect origin)	Sediment (eg. mud/sand/shell)	Comments (eg 10x gastropods, 4x crab holes, dugong feeding trails, herbarium specimen taken)	Seagrass coverage (%)	% Seagrass species composition			Canopy height (cm)	% Algae cover	% Epi- cover
				HO	HU	ZC			
1 (0m)	Sand	SC x 3 HC x 1	40	30	70		514.17	5	33
2 (5m)	S	GAB x 3	33	50	50		1017.8	10	18
3 (10m)	mud/sand	worm x 1	18	70	20	10	618.5	0	48
4 (15m)	m s	DFT x 1	0				0	17	0
5 (20m)	m s shell	HC x 3	36	5	90	5	917.5	12	57
6 (25m)	m s sh	Turtle cropping	48	100			NA.	2	96
7 (30m)	Fine Sand		0				1.5cm	23	0
8 (35m)	FS	SC x 2 CH x 3	0.7		100		717.7	18	31
9 (40m)	S m		23	96	4		214.6	6	17
10 (45m)	m	Mudworek x 2 HC x 1	41	2	95	3	551.6	3	21
11 (50m)	m s		16	3	7	90	716.7	38	6

END of transect (GPS reading)

Latitude:  $25^{\circ} 11.2656$ , S Longitude:  $152^{\circ} 37.5546$ , E

SC = Sea Cucumbers  
 GAB = Gastropod  
 DFT = Dugong feeding trail  
 HC = Hermit Crab  
 CH = Crab Hole

# How to use a compass

Modified from Kjetil Kjernsmo <http://www.learn-orienteeing.org/old/lesson1.html>

The most important thing you first need to learn before using a compass are the directions **North, South, East and West**. Look at the figure below and learn how they are. **North** is the most important. *Remember the sun rises in the east and sets in the west.*

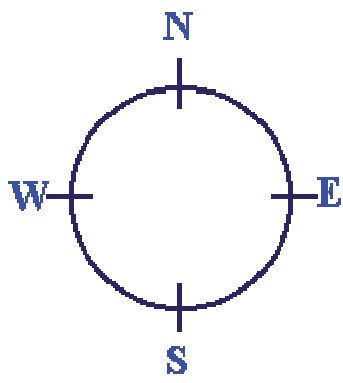

A type of compass often used in Seagrass-Watch is an orienteering compass. It has a large rectangular base-plate (often of clear rigid plastic), on which is a large red travel arrow. Attached to the base-plate is a turnable dial.

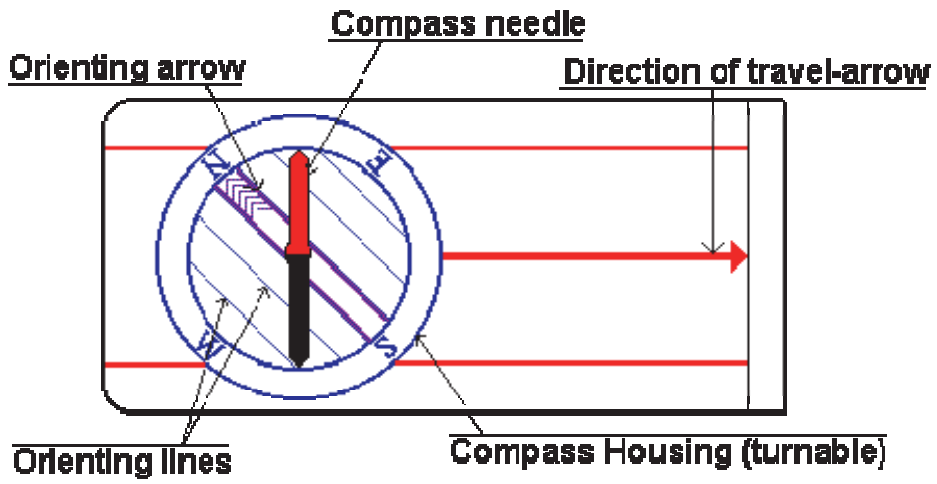

The turnable dial on the compass is called the *Compass housing*. On the edge of the compass housing is a scale from 0 to 360. These are the degrees or the *azimuth*. Also on the housing are the letters N, S, W and E for North, South, West and East.

Within the compass housing is a red and black arrow, called the *compass needle* (on some compasses it might be red and white). **The red part of the needle always points towards the earth's magnetic north pole.**

To find a direction using the compass, you first turn the compass housing until the direction you desire comes exactly in line with the travel arrow, then holding the compass flat, you then turn the whole compass until the compass needle is aligned within the orienting arrow and the red end of the needle points to **N** (north).

For example, if you have arrived at your site and want to lay out transect 2 at bearing (compass heading) of 320 degrees, you first turn the compass housing so that 320 on the housing comes exactly in line with where the large *direction of travel*-arrow meets the housing.

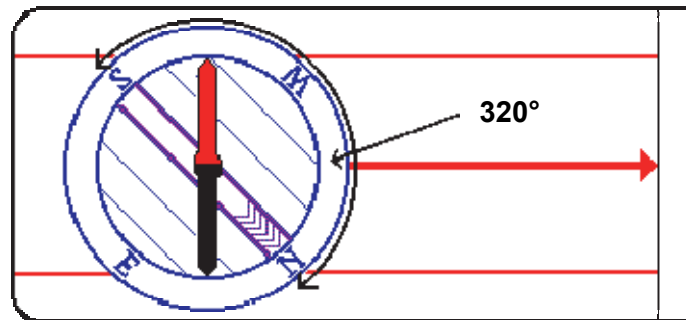

Hold the compass flat in your hand so that the compass needle can turn freely. Then turn yourself, your hand, the entire compass (*make sure the compass housing doesn't turn*), until the compass needle is aligned with the orienting arrow lines inside the compass housing.

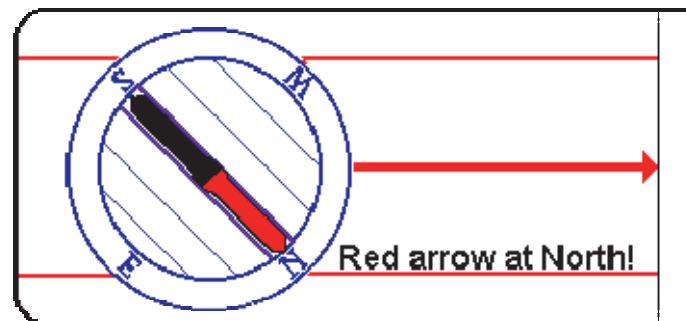

It is *extremely* important that the red (**N**orth) part of the compass needle points to **N**orth in the compass housing. If the red points to the **S**outh, you would walk off in the exact opposite direction of what you want!

A problem can occur if there is a local magnetic attraction. For example, if you are carrying something of iron, it might disturb the arrow. Even a staple in your book might be a problem. Make sure there is nothing of the sort around. There is a possibility for magnetic attractions in the soil as well, "magnetic deviation", but they are rarely seen.

If the needle is directly aligned, you should now be facing 320 degrees. When you are sure you've got it right, fix your eye on some special feature on the horizon (e.g., a rock or coral) with the travel arrow and now head for it. If you are directing someone, keep them informed and line them up with hand signals when they reach the 50m mark.

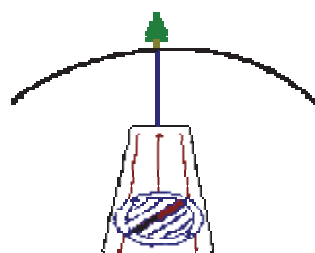

When standing at the start of transect 2 and you want to find the start of transect 1, you need to change your compass bearing by subtracting 90 from the transect bearing (e.g., in the previous example,  $320-90= 230$ ). Measure 25m from the start of transect 2, heading 230 degrees, and put in the peg. This is the start of transect 1. Lay out transect 1 using the same procedure as you just completed for transect 2 (heading 320).

To locate the start of transect 3, you need to change your compass bearing by adding 90 from the transect bearing (e.g., in the previous example,  $320+90 = 410$ , but as only 360 in a compass your bearing will be 50). Measure 25m from the start of transect 2, heading 50 degrees, and put in the peg. This is the start of transect 3. Lay out transect 3 using the same procedure as you just completed for both transects 1 and 2 (heading 320).

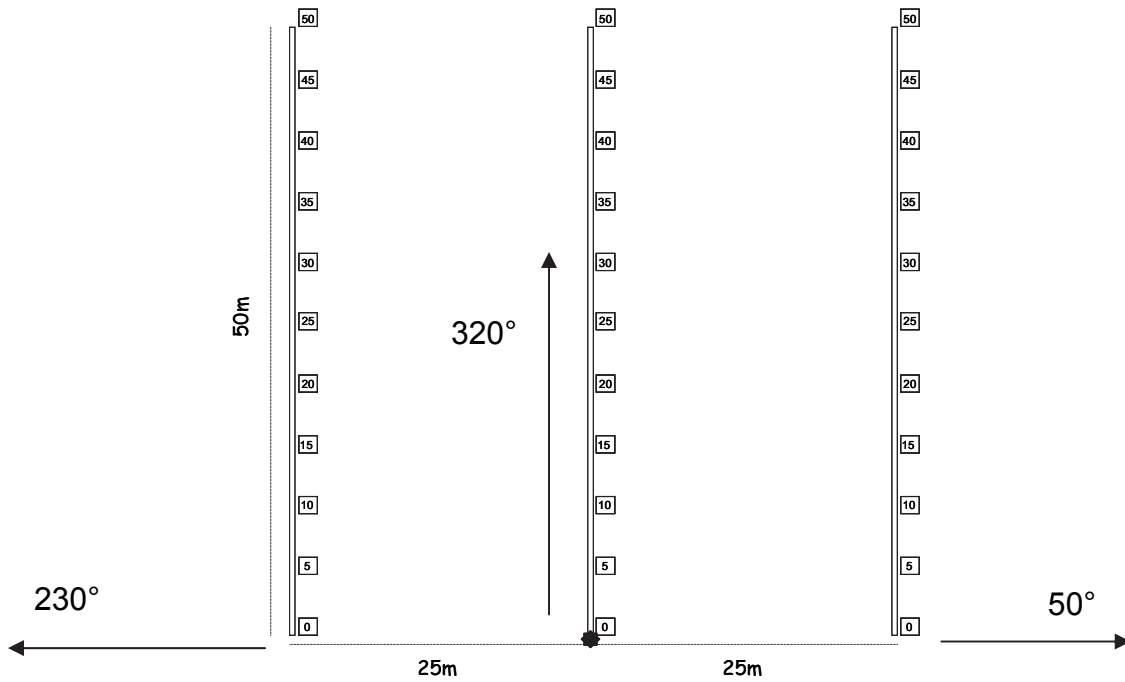

# Making a herbarium press specimen

Herbaria are repositories of preserved and labelled plant specimens, arranged to allow easy access and archival storage. The specimens are typically in the form of herbarium sheets: pressed and dried plants that have been attached to a sheet of heavy paper together with a data label. A herbarium specimen is simple in form and low-tech in preparation, yet it preserves a wealth of valuable information. If properly stored, a herbarium specimen will last for centuries without much deterioration. Specimens document the variation in form and geographical range of species. Herbaria also document valuable historical collections, such as "type specimens", the original specimens on which a plant's Latin name is based. Many herbarium specimens record the existence of plants in habitats now developed and lost.

## COLLECTION

Before collecting any seagrass specimens, ensure you have the appropriate permits. All flora that is native to Western Australia is protected throughout the State under the Wildlife Conservation Act. Protected Flora is defined as *any plant and includes any part of a plant including seeds and spores*. To take flora from Crown land<sup>2</sup> for non-commercial purposes a Scientific or Other Prescribed Purposes Licence is required. This licence covers activities such as research, or non-commercial propagation for revegetation projects, or for recreational and hobby purposes. A copy of the application form and information sheet is attached.

In the field, collect a handful of representative seagrass shoots, including the leaves, rhizomes and roots. Keep in mind that it is not always possible to get a successful classification if you do not have particular parts such as flowers, fruits, seeds and roots, so try to select shoots which have these features. Ideally, collect plants with growing tips (meristems) as they contain higher concentrations of DNA which could aid genetic identification in the future.

Specimens should be pressed as soon as possible after collection. If it is more than 2 hours before you press the specimen, then you should refrigerate to prevent any decomposition. Do not refrigerate longer than 2 days, press the sample as soon as possible.

## PRESSING

### Tools

First you will need some clean white cartridge-type paper (photocopy paper will suffice) and herbarium sheets (if available). You will also need forceps, scissors/scalpel, a dish of clean fresh water and a herbarium press. It is not difficult to build a home-made press, keeping in mind that what must be accomplished is to keep the specimens squeezed between layers of paper (newspapers or blotting paper) until they are totally devoid of the original content of water. The upper and lower parts of the press might be made of heavy cardboard or thick plywood or equivalent material. A more advanced kind of press might be built for an optimal drying of your plants. This press can be made with two wooden boards with screws and nuts placed at each corner: turning the nuts the two boards will come closer pushing together the paper with the plants. This kind of press can be built at home or bought in some art tools stores.

### Preparation

Wash the seagrass specimen in clean fresh water and carefully remove any debris, epiphytes or sediment particles.

---

<sup>2</sup> Crown Land refers to "All land, not being alienated land, within the limits of the State of Western Australia that form the airspace, seabed and subsoil of marine waters and coastal waters as defined under the Commonwealth's Coastal Waters (State Powers) Act 1980".

## Arrangement

It is very important that the seagrass specimen be arranged so that you can immediately see all the main characters of that particular species; so do not focus only at the aesthetics of the mounted specimen. It is advisable to arrange specimens before being placed in the press as once dried, plant specimens can easily be broken if handled without care. The best manner to place the plants on the mounting sheets is to align them with the right side of the page (or diagonally if space is required) and to have the heaviest parts and specimens at the bottom. Leaves can be folded in larger specimens if a larger press is not available. It is better to leave an empty space at the borders of the mounting sheets; but you can either arrange your specimens (along with the label) in a regular way from page to page, or stagger the specimens at different positions on each sheet, so that each group of sheets will have a more equally distributed pressure.

## Labels

Each specimen must have a label on its own sheet, which should include the taxonomic denomination (*at least family, genus and species*) along with information on the date and place of collection. The name of the collector and of the individual who did the determination should also be added. Use permanent and water resistant ink (black or blue) to write your labels; otherwise a pencil can be used (medium lead). Specimen labels should include:

- species name (*if known*)
- location & site code (*if applicable*)
- date collected
- latitude/longitude
- water depth
- % seagrass cover
- sediment type
- other seagrass species present
- name of collector and who identified the specimen
- comments -*such as presence of flowers/fruits or ecological notes*

Place the label on the lower right hand corner of the paper.

## Drying

Place another clean sheet of paper over the specimen and place within several sheets of newspaper. As circulating air is very important to get your specimens dried in a short time, the assemblage of specimen/paper should be placed within two sheets of corrugated cardboard and then into a herbarium press. Corrugated cardboard ensures air can penetrate and speed up the drying process. If no corrugated cardboard is available, keep the filled press size small.

Once in the herbarium press, wind down the screws until tight (*do not over tighten*). If you do not have a press, the specimens can be pressed by putting some heavy object on top, i.e. bricks or large books. It is important that the plants are put under sufficient pressure; otherwise more time will be required to achieve a good desiccation, besides they could be damaged by dampness and moulds.



The press should be exposed to a gentle heat source, avoiding excessive heat that will "cook" the specimens. Sometimes it is possible to use the heat from the sun. In this case the presses should be small. If fire is the heat source, keep the press at a safe distance to prevent fire starting on the press.

Changing the paper is a very important step. In the first three or four days a paper change should take place every day, then you can leave more time between changes. If you neglect the change of paper the plants will take more time to lose their water content, besides they could be damaged if the paper stays wet for a few days. When changing the paper you must keep the specimens intact and ensure the label travels with the specimen. The minimum time required for complete drying ranges from two to four days or more. Once a specimen has become dry and stiff, it can be mounted and placed into the herbarium.

## Mounting

Once the specimen is completely dry, you will need to mount it to herbarium sheets if available or a new clean white cartridge-type paper.

There are different ways to mount the specimens to the herbarium sheets, such as strapping, gluing, pinning or nothing. We recommend the strapping method using removable adhesive tape (eg Magic Tape). The tape pulls off easily, leaves behind no messy residue, and can be pulled up and moved around. To fix the specimen to the mounting paper, lay small strips of tape across a few sturdy parts of the plant (eg either end of rhizome or a stem) at a minimal number of points. This method will allow a certain degree of movement for further examinations, but the specimen will not fall from the mounting paper

## HERBARIA

Once the specimen is mounted it can be stored in a dry place or lodged in Herbaria. If you do not have a Herbaria in your region or state (usually located at a University or Government agency), you can submit specimens to Seagrass-Watch HQ which maintains a Herbaria as part of the Australia Tropical Herbarium.

Alternatively, you can email a scanned image of the pressed specimen. Please ensure that the scanned image is no less than 600 dpi and includes the specimen and label. Scanned images can be sent to [hq@seagrasswatch.org](mailto:hq@seagrasswatch.org) and will be lodged in the Seagrass-Watch Virtual Herbarium <http://www.seagrasswatch.org/herbarium.html>.

The Virtual Herbarium is an electronic gateway to the collections of the Seagrass-Watch HQ herbaria. The goals of the Virtual Herbarium are to make specimen data available electronically for use in biodiversity research projects; to reduce transport of actual specimens for projects where digital representations will suffice for study; and to provide a source of reference information for Seagrass-Watch participants.





RECEIPT NUMBER:

## APPLICATION FOR A LICENCE FOR SCIENTIFIC OR OTHER PRESCRIBED PURPOSES TO TAKE PROTECTED FLORA FROM CROWN LAND FOR NON-COMMERCIAL PURPOSES

Completed forms should be returned to Department of Environment and Conservation, Locked Bag 104 Bentley Delivery Centre WA 6983, or a local DEC receiving office, together with the prescribed fee of \$10.00

<b>APPLICANT:</b> Surname Dr/Mr/Mrs/Miss/Ms		Other Names
Address (residential)		Postcode
Address (postal)		Postcode
Address Change Yes/No (please state previous address)		Date of Birth / /
Day Phone No.	Associated Research Institution (if applicable)	

**PURPOSE FOR WHICH LICENCE SOUGHT (TICK BOX)**

Scientific       Educational       Hobby       Non-commercial propagation       Personal Enjoyment

**GIVE DETAILS OF YOUR PROPOSED USE OF FLORA (or attach research proposal)**

**ACTIVITIES:**      Taxonomy       Inventory       Biochemical Analysis       Rehabilitation       Plant Breeding

**LAND TO WHICH APPLICATION RELATES - IDENTIFY SEPARATELY**

Name of Local Authority (eg. Shire)	Location of Crown Land: (eg. Reserve or Location No. or Reserve/Forest Block Name )	Vesting (Managing) Authority (Government Agency)

**FLORA TO WHICH APPLICATION RELATES (If insufficient space attach list):**

Scientific Name	Common Name (if any)	Parts to be taken (e.g. Flowering Stems, Fruits (Nuts), Seeds, Leaves, Cuttings)

If applicable, state period for which licence will be required:

--

**SIGNATURE OF APPLICANT** ..... **DATE** ...../...../.....

Applicants are advised that it is an offence under the Wildlife Conservation Regulations 1970 to directly or indirectly sell or otherwise dispose of for gain or reward any protected flora taken under a licence for scientific or other prescribed purposes.

A **Scientific or Other Prescribed Purposes (SOPP) Licence** allows the taking of protected **flora** from Crown land for non-commercial purposes. Protected flora is defined as any plant that is native to Western Australia or declared to be under the Wildlife Conservation Act, and includes any part of the plant and all seeds and spores thereof.

This type of licence does not authorise the taking of Declared Rare Flora (DRF). Permission from the Minister for Environment is required to collect DRF, and further advice on this matter can be sought through DEC's Species and Communities Branch.

Standard conditions of the SOPP licence do not allow the taking of flora in a manner that destroys or jeopardises the survival of the plant, population or associated vegetation. The taking of whole plants and roots is also not permitted under standard conditions.

When completing the SOPP application please note the following:

#### **PROPOSED USE OF FLORA**

Details of why collection of flora is required must be explained in the application.

Should it be for "Scientific" purposes, a research proposal stating the parts, quantities to be taken and reasons for collecting, must be attached to your application with a supporting letter from your associated research institution. It is important to state if your research will require the taking of roots or whole plants, so that if your licence is approved, the standard conditions can be amended to permit this activity.

#### **LAND TO WHICH APPLICATION RELATES**

This Licence relates to the collecting of flora from Crown land only. Written authority from the land manager must be obtained prior to the collection of flora.

This licence does not allow the taking of flora from DEC reserves (e.g National Parks, Nature Reserves). If it is necessary to take flora from DEC reserves for your studies, you will need to apply for a Regulation 4 entry permit through the Wildlife Licensing Section.

#### **SPECIMEN LODGEMENT**

Those applying for a licence for the prescribed purpose of "Scientific" must note that all holotypes and isotypes, where collected, and duplicate specimens of all other material collected must be lodged at the Western Australian Herbarium (PERTH).

It is recommended that you contact the Collection Manager, Ms Karina Knight at the WA Herbarium on 9334 0500 to discuss vouchering procedures and requirements prior to collection.

#### **REPORTS**

Those issued with a Licence for the prescribed purpose of "Scientific" may be required to submit a report of activities undertaken during the currency of the licence.

Should you be required to submit a report, within one month of the expiration of the licence, a report setting out in full detail the number of each species of flora taken, the localities where the species was/were taken and the method of collection and where the specimens were lodged needs to be forwarded to DEC's Wildlife Licensing Section. A copy of any paper or report resulting from this research should also be submitted in due course.

#### **RENEWAL OF LICENCE**

Renewal of licence is the responsibility of the licensee and will not automatically be granted. Each request for renewal is to be treated as a new application, so that in the event circumstances change, the appropriate licence conditions can be issued.

It is recommended that requests for renewal be sent one (1) month prior to the expiry date shown on the licence, to allow time for processing and posting.



# Flora Licensing Information Sheet

---

## TAKING FOR SCIENTIFIC OR OTHER PRESCRIBED PURPOSES

All flora that is native to Western Australia is protected throughout the State under the Wildlife Conservation Act. Protected Flora is defined as any plant (including any wildflower, palm, shrub tree, fern, creeper or vine) and includes any part of a plant including seeds and spores.

### CROWN LAND

To take flora from Crown land for **non-commercial purposes** a Scientific or Other Prescribed Purposes Licence is required. This licence covers activities such as research, or non-commercial propagation for revegetation projects, or for recreational and hobby purposes. Once a licence is issued, written permission from the land manager must be obtained prior to collection.

The normal fee for this licence is \$10. However, if you are proposing to collect flora as a member of an educational institution to benefit the States' knowledge of its flora and conservation or if you propose to collect as part of your required course of study a waived fee licence may be applied for.

To take flora from Crown land (Shire Reserves, Pastoral leases, Unallocated Crown land etc.) **for sale, as exchange for goods or services, or as part of your paid work duties when a commercial gain is accrued from the collection/taking of protected flora** a Commercial Purposes Licence is required. The licence fee is \$100 and is valid for 1 year. Written authority to collect the flora must be obtained from the land manager and attached to the application. Please note that taking of flora for commercial purposes from conservation estate (e.g. National Parks, Nature Reserves, Conservation Parks) is not permitted.

### PRIVATE PROPERTY

The taking of Protected Flora for **non-commercial purposes** from private property does not require a licence, however you must obtain the landowner's permission prior to collection.

### INFORMATION TO BE SUPPLIED BY THE APPLICANT

An application form for a Scientific or Other Prescribed Purposes Licence must be completed by every person who wishes to collect protected flora. If you are applying for a waived fee licence, a letter of support from your educational institution or organisation is also required. If the purpose of your licence does not allow for the listing of species to be taken or proposed land to which the application relates, a cover letter from your organisation (ie. Consultancy or Regional Herbarium) should accompany the application.

This type of licence does not authorise the taking of Declared Rare Flora (DRF). Permission from the Minister for Environment is required to collect DRF, and further advice on this matter can be sought through DEC's Species and Communities Branch. Standard conditions of the SOPP licence do not allow the taking of flora in a manner that destroys or jeopardises the survival of the plant, population or associated vegetation. The taking of whole plants and roots is also not permitted under standard conditions.

When completing the SOPP application please note the following:

---

---

## **PROPOSED USE OF FLORA**

Details of why collection of flora is required must be explained in the application. Should it be for “Scientific” purposes, a research proposal stating the parts, quantities to be taken and reasons for collecting must be attached to your application with a supporting letter from your associated research institution. It is important to state if your research will require the taking of roots or whole plants, so that if your licence is approved, the standard conditions can be amended to permit this activity.

## **LAND TO WHICH APPLICATION RELATES**

This Licence relates to the collecting of flora from Crown land only. Written authority from the land manager must be obtained prior to the collection of flora.

This licence does not allow the taking of flora from lands managed by the Department of Environment and Conservation (DEC). For example National Parks, Nature Reserves, State Forest etc. If it is necessary to take flora from DEC lands for your research activities, you will need to apply for a Regulation 4 entry permit through the Wildlife Licensing Section.

## **SPECIMEN LODGEMENT**

Those applying for a licence for the prescribed purpose of “Scientific” (ie, for research) must note that all holotypes and isotypes, where collected, and duplicate specimens of all other material collected must be lodged at the Western Australian Herbarium (PERTH). It is recommended that you contact the Collection Manager, Ms Karina Knight at the WA Herbarium on 9334 0500 to discuss vouchering procedures and requirements prior to collection.

## **REPORTS**

Those issued with a Licence for the prescribed purpose of “Scientific” may be required to submit a report of activities undertaken during the currency of the licence.

Should you be required to submit a report, within one month of the expiration of the licence, a report setting out in full detail the number of each species of flora taken, the localities where the species was/were taken and where the specimens were lodged needs to be forwarded to DEC’s Wildlife Licensing Section. Copies of any papers or reports resulting from this research should also be submitted when completed. “Scientific” collection for non-commercial rehabilitation programs under a SOOPP licence requires a completed 3 monthly return form to be submitted.

For consultants, a copy of any paper or report resulting from licensed collections must be submitted as the report of activities conducted under the licence period.

## **RENEWAL OF LICENCE**

Renewal of licence is the responsibility of the licensee and will not automatically be granted. Each request for renewal is to be treated as a new application, so that in the event circumstances change, the appropriate licence conditions can be issued.

It is recommended that requests for renewal be sent one (1) month prior to the expiry date shown on the licence, to allow time for processing and posting.

## **FURTHER INFORMATION**

Further information and application forms can be obtained from DEC’s Naturebase website [http://www.calm.wa.gov.au/plants\\_animals/licensing/flora\\_licensing.html](http://www.calm.wa.gov.au/plants_animals/licensing/flora_licensing.html) or by contacting DEC’s Wildlife Licensing Section on 9423 2441.

Completed applications should be returned to the Department of Environment and Conservation, Locked Bag 30, Bentley Delivery Centre, 6983, or a local DEC receiving office, together with the prescribed fee stated on the application form.

# Understanding sediment

Seagrasses, especially structurally large species, affect coastal and reef water quality by trapping sediments and acting as a buffer between catchment inputs and reef communities. Seagrass meadows have the ability to modify the energy regimes of their environments, and help stabilise sediment by trapping and binding the sediment. However, the trapping ability of seagrass is in reality an equilibrium established between deposition/sedimentation and erosion/resuspension.

Studies have shown that sediment characteristics are important in determining seagrass growth, germination, survival, and distribution. As part of Seagrass-Watch, field descriptions of sediment type collected 0-2 cm below the sediment/water interface are determined by visual and tactile inspection of (wet) samples and constituents (primary descriptors) differentiated according to the Udden – Wentworth grade scale.

## **Grain size classes used, based on the Udden – Wentworth grade scale of Wentworth (1922).**

	Fine-medium Clay	0 – 0.002 mm
	Coarse Clay	0.0021 – 0.004 mm
<b>Mud</b>	Very Fine Silt	0.0041– 0.008 mm
	Fine Silt	0.0081 – 0.016 mm
	Medium Silt	0.0161 – 0.031 mm
	Coarse Silt	0.0311 – 0.063 mm
	<hr/>	
	Very Fine Sand	0.0631 – 0.125 mm
	Fine Sand	0.1251 – 0.250 mm
<b>Sand</b>	Medium Sand	0.2501 – 0.500 mm
	Coarse Sand	0.5001 – 1.000 mm
	Very Coarse Sand	1.0001 – 2.000 mm
<hr/>		
<b>Gravel</b>	Granules	2.0001 – 4.000 mm
	Pebbles and larger	>4.0001 mm

In Seagrass-Watch, the primary descriptors relate to the size of the sediment grains: gravel (>2000µm); coarse sand (>500 µm); sand (>250 µm); fine sand (>63 µm); and mud (<63 µm).

The sediment **Primary Descriptors** are written down from left to right in decreasing order of abundance: e.g. Mud/Sand is mud with sand, where mud is determined as the dominant constituent (by volume).

<b>mud</b>	<i>has a smooth and sticky texture.</i>
<b>fine sand</b>	<i>fairly smooth texture with some roughness just detectable. Not sticky in nature.</i>
<b>sand</b>	<i>rough grainy texture, particles clearly distinguishable.</i>
<b>coarse sand</b>	<i>coarse texture, particles loose.</i>
<b>gravel</b>	<i>very coarse texture, with some small stones.</i>

Sediment type **Modifiers** are also commonly used, however these are recorded in the comments section. Modifiers include: coral, shell grit, forams, diatoms, etc.

The visual/tactile estimation method used in Seagrass-Watch is a simple yet relatively accurate measure of the sediment grain size which can be used for quantitative assessments (see McKenzie 2007, [http://www.seagrasswatch.org/Info\\_centre/Publications/pdf/371\\_DPIF\\_McKenzie.pdf](http://www.seagrasswatch.org/Info_centre/Publications/pdf/371_DPIF_McKenzie.pdf)).

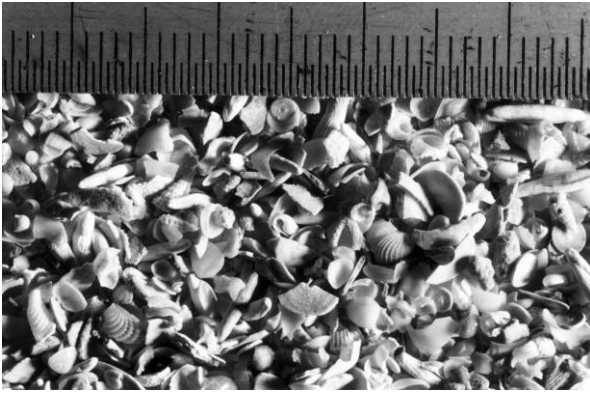

gravel (>2mm)

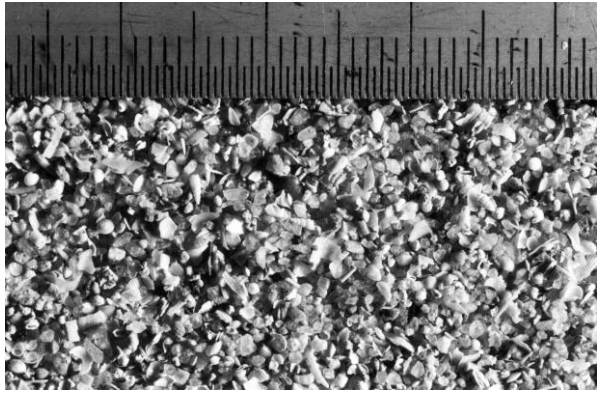

very coarse sand (1 - 2 mm)

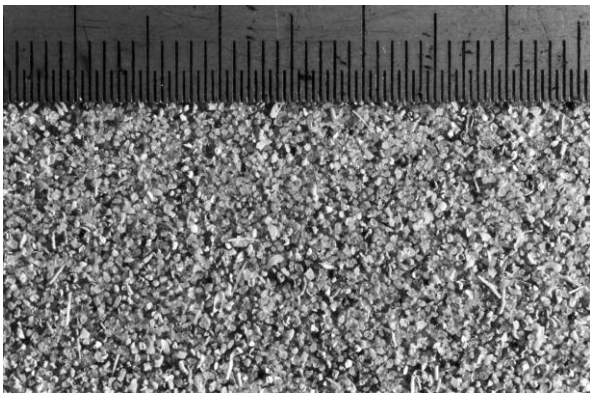

coarse sand (0.5 - 1 mm)

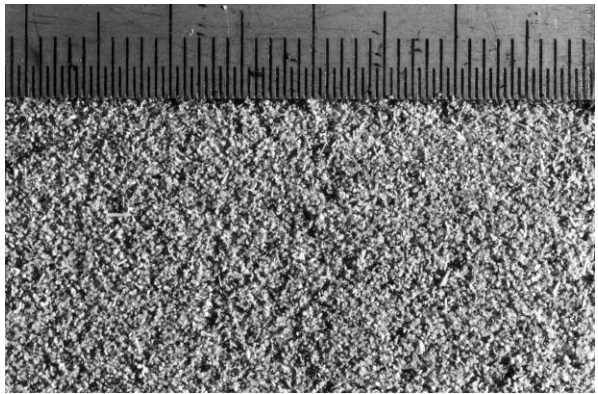

medium sand (0.25 - 0.5 mm)

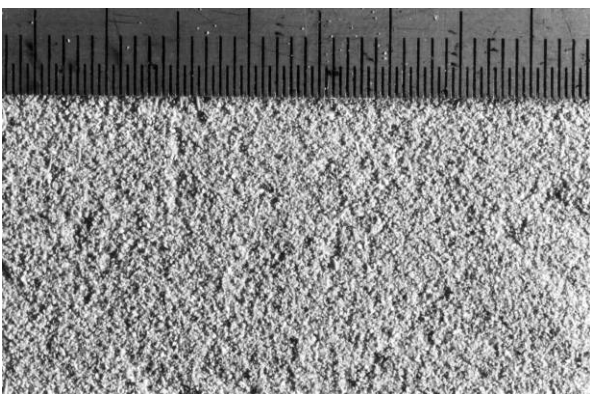

fine sand (0.125 - 0.25 mm)

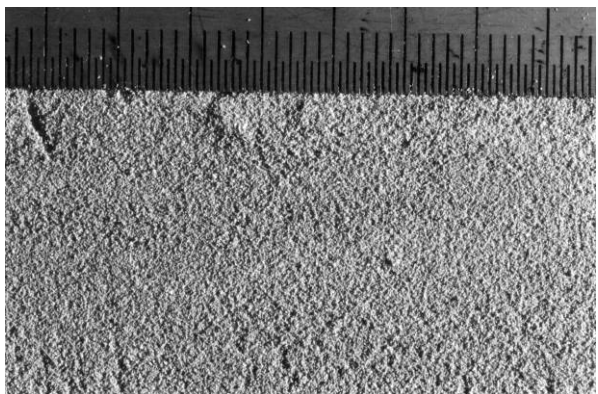

very fine sand (0.063 - 0.125mm)

**Notes:**

.....

.....

.....

.....

.....

# Data entry

All data collected in the Seagrass-Watch program is the property of the group (principal) who collected it, and Seagrass-Watch HQ is custodian. When a group submits data to HQ, it does so under the proviso that the data can be used by Seagrass-Watch HQ for condition and trend reporting at location, regional, state, national and global scales (eg, State of the Environment). Copies of raw data are provided to third parties only when permission from the principal is provided.

All data interpretation is conducted by Seagrass-Watch HQ. This ensures that the interpretation of data is consistent, unbiased and of scientific merit. Seagrass-Watch HQ also encourages peer review and assessment of published results.

Once you have monitored your Seagrass-Watch site, you can now enter the data collected into a downloadable Microsoft Excel spreadsheet and submit via email.

To enter the data, first go to the website [http://www.seagrasswatch.org/data\\_entry.html](http://www.seagrasswatch.org/data_entry.html) and click on the datasheet image

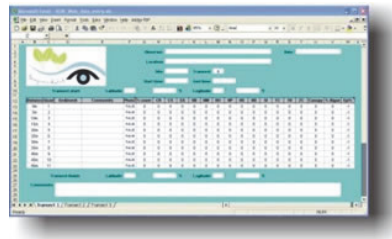

- Save the spreadsheet file to your computer before you begin data entry. We suggest changing the file name to the site code and the sampling date, eg if the site was Town Beach, and it was sampled on 16 October 2011 then the filename would be "RO1\_16Oct11.xls"
- The spreadsheets are a similar layout to the standard datasheets. Each transect has its own worksheet. To select the appropriate worksheet, click on the tab at the bottom
- To enter data, select each cell with your mouse. You can jump between cells by using the TAB button on your keyboard.
- First enter the name of the observers and the sampling date.
- Enter the location and site code. For the above example, the location is "Town Beach" and the site code is "RO1".
- Enter the time you started sampling the transect and the time you finished. Times are entered at 24 hr with the hour separated from the minutes by a colon. For example, if the time was half past one in the afternoon, the time entered would be "13:30".
- If you had a GPS (Global Positioning System) at the monitoring site, the latitude and longitude of the transect start

- Enter the data for each quadrat

*Sediment*: enter by the dominant grain size first, separating sediment categories by a forward slash. For example, if the quadrat was predominantly mud with some sand, then the data would be entered as "Mud/Sand". *Please do not use abbreviations "M/S" when entering into the spreadsheet.*

*Comments*: Enter information (including counts) of any features which may be of interest. For example, "sea cucumbers (x2), sea urchin (x1), evidence of turtle cropping"

*Photograph*: type in "True" if you took a photo of the quadrat

*% cover*: enter the total percent cover of seagrass within the quadrat

*% cover by species*: enter the percentage cover that each species contributes to the total cover

*Photograph*: type in "True" if you took a photo of the quadrat

*% cover*: enter the total percent cover of seagrass within the quadrat. *There is no need to write %.*

*% cover by species*: enter the percentage cover that each species contributes to the total cover

*Canopy*: enter the three canopy heights of the dominant strap leaf species (*the average will calculate automatically*)

*% Algae*: enter the percent cover of macro-algae in the quadrat. Macro-algae are seaweeds that are not attached to seagrass leaves and may even overlie the seagrass shoots. The combined seagrass and algae cover may be greater than 100%.

*Epi %*: Enter the percentage cover of epiphytes on the total seagrass leaves.

- Enter the latitude and longitude of the transect finish
- Enter any general comments about the transect or site
- **Repeat steps 5 to 10 for the remaining transects**
- Ensure your file is securely saved

Submit a copy of the excel file via internet to Seagrass-Watch HQ [hq@seagrasswatch.org](mailto:hq@seagrasswatch.org)

Mail original datasheets, photos and herbarium sheets to

**Seagrass-Watch HQ**

PO Box 5396

Cairns Qld 4870

AUSTRALIA



# Managing seagrass resources

## Threats to seagrass habitats

Destruction or loss of seagrasses have been reported from most parts of the world, often from natural causes, e.g., "wasting disease" or high energy storms. However, destruction commonly has resulted from human activities, e.g., as a consequence of eutrophication or land clamation and changes in land use. Increases in dredging and landfill, construction on the shoreline, commercial overexploitation of coastal resources, and recreational boating activities along with anthropogenic nutrient and sediment loading has dramatically reduced seagrass distribution in some parts of the world. Anthropogenic impacts on seagrass meadows continue to destroy or degrade coastal ecosystems and decrease the function and value of seagrass meadows including their contribution to fisheries. It is possible global climate change will have a major impact. Efforts are being made toward rehabilitation of seagrass habitat in some parts of the world: transplantation, improvement of water quality, restrictions on boating activity, fishing and aquaculture, and protection of existing habitat through law and environmental policy.

## Management

Seagrasses do not exist in nature as a separate ecological component from other marine plants and are often closely linked to other community types. In the tropics the associations are likely to be complex interactions with mangrove communities and coral reef systems. In temperate waters, algae beds, salt marshes, bivalve reefs, and epiphytic plant communities are closely associated with areas of seagrass. Many management actions to protect seagrasses have their genesis in the protection of wider ecological systems or are designed to protect the overall biodiversity of the marine environment.

Seagrasses are also food for several marine mammal species and turtles, some of which (such as the dugong *Dugong dugon* and green turtle *Chelonia mydas*) are listed as threatened or vulnerable to extinction in the IUCN Red List ([www.iucnredlist.org](http://www.iucnredlist.org)). Seagrasses are habitat for juvenile fish and crustaceans that in many parts of the world form the basis of economically valuable subsistence and/or commercial fisheries. The need to manage fisheries in a sustainable way has itself become a motivating factor for the protection of seagrasses.

Methods of direct protection range from legislative instruments and associated legal sanctions through to education (Coles & Fortes 2001). These can be separated into three approaches: a proscriptive legal approach; a non-proscriptive broad based approach ranging from planning processes to education; and a reactive approach designed to respond to a specific issue such as a development proposal. These may overlap and be used simultaneously in many cases. It is these three approaches that Seagrass-Watch supports for the protection/conservation of seagrass.

### *Reactive (on-ground)*

Reactive processes generally occur in response to a perceived operational threat such as a coastal development proposal (Coles & Fortes 2001). Reactive processes can include port contingency planning, risk management plans and environmental impact assessments.

### *Prescriptive (legal)*

Prescriptive management of seagrass issues can range from local laws to a Presidential Decree, or Executive Order. Laws can directly safeguard seagrasses

or can protect them indirectly by protecting habitat types (all aquatic vegetation) or by influencing a process, eg., prevention of pollution (Coles & Fortes 2001).

In some locations, protection is often strongest at the village or community level. This may be by Government supported agreements or through local management marine area level. In these cases successful enforcement is dependent on community support for the measure.

#### *Non-prescriptive (planning & education)*

Non-prescriptive methods of protecting seagrasses are usually part of planning processes and may have a strong extension/education focus (Coles & Fortes 2001). Providing information is important as it enables individuals to voluntarily act in ways that reduce impacts to seagrasses. Non-prescriptive methods range from simple explanatory guides to complex industry codes of practice.

Coastal management decision making is complex, and much of the information on approaches and methods exists only in policy and legal documents that are not readily available. There may also be local or regional Government authorities having control over smaller jurisdictions with other regulations and policies that may apply. Many parts of South East Asia and the Pacific Island nations have complex issues of land ownership and coastal sea rights. These are sometimes overlaid partially by arrangements put in place by colonising powers during and after World War II, leaving the nature and strength of protective arrangements open for debate.

Both Australia and the United States have developed historically as Federations of States with the result that coastal issues can fall under State or Federal legislation depending on the issue or its extent. In contrast, in Europe and much of South East Asia, central Governments are more involved. Intercountry agreements in these areas such as the UNEP Strategic Action Plan for the South China Sea and the Mediterranean Countries Barcelona Convention (<http://www.unep.org/>) are required to manage marine issues that encompass more than one country.

Approaches to protecting seagrass tend to be location specific or at least nation specific (there is no international legislation directly for seagrasses as such that we know of) and depend to a large extent on the tools available in law and in the cultural approach of the community. There is, however, a global acceptance through international conventions (RAMSAR Convention; the Convention on Migratory Species of Wild Animals; and the Convention on Biodiversity) of the need for a set of standardised data/information on the location and values of seagrasses on which to base arguments for universal and more consistent seagrass protection.

Indigenous concepts of management of the sea differ significantly from the introduced European view of the sea as common domain, open to all and managed by governments (Hardin 1968). Unlike contemporary European systems of management, indigenous systems do not include jurisdictional boundaries between land and sea. Indigenous systems have a form of customary ownership of maritime areas that has been operating in place for thousand of years to protect and manage places and species that are of importance to their societies.

Marine resource management these days should, therefore, attempt to achieve the following interrelated objectives: a) monitor the wellbeing (e.g. distribution, health and sustainability) of culturally significant species and environments (e.g. dugong, marine turtles, fish, molluscs, seagrass etc.); and b) monitor the cultural values associated with these culturally significant species and environments (Smyth et al. 2006).

To realize objective a) we believe the following also needs to be accomplished if the successful management of coastal seagrasses is to be achieved.

1. Important fish habitat is known and mapped
2. Habitat monitoring is occurring
3. Adjacent catchment/watershed impacts and other threats are managed
4. Some level of public goodwill/support is present
5. Legal powers exist that are robust to challenge
6. There is effective enforcement and punishment if damage occurs

The key element is a knowledge base of the seagrass resource that needs to be protected and how stable/variable that resource is. It is also important to know if possible any areas that are of special value to the ecosystems that support coastal fisheries and inshore productivity. It is important as well that this information is readily available to decision makers in Governments in a form that can be easily understood.

Consequently a combination of modern “western” science and indigenous knowledge should be brought together within a co-management framework for the successful management of these resources. (Johannes 2002; Aswani & Weiant 2004; Turnbull 2004; Middlebrook and Williamson 2006; Gaskell 2003, George et al. 2004). This can only occur if the resource owners actively involve themselves in the management of their resources. Western science also needs to recognise that resource owners have practical and spiritual connections with the resources found within their environment. Once this is recognized then this approach will have the added benefit of empowering communities who own the knowledge to be the primary managers and leaders in decisions about their land and sea country.



# References

- Adam SA (2003) The dugongs of One Arm Point, the Kimberly, Western Australia. <http://www.sirenian.org/kimberly.html>
- Anon (2008). The North-west Marine Bioregional Plan Bioregional Profile. A Description of the Ecosystems, Conservation Values and Uses of the North-west Marine Region. Australian Government Department of the Environment, Water, Heritage and the Arts. 273pp.
- Aswani, S., Weiant, P. (2004). Scientific evaluation in women's participatory management: monitoring marine invertebrate refugia in the Solomon Islands. *Human Organisation* **63** (3), 301-319.
- Costanza R, d'Arge R, de Groot R, Farber S, Grasso M, Hannon B, Limburg K, Naeem S, O'Neil RV, Paruelo J, Raskin RG, Sutton P and van der Belt M. (1997). The Value of the world's ecosystem services and natural capital. *Nature* **387**(15): 253-260.
- de Goeij, P., Lavaleye, M., Pearson, G.B. and Piersma, T. (2003). Seasonal changes in the macro-zoobenthos of a tropical mudflat. NIOZ-Report 2003-4. (Royal Netherlands Institute for Sea Research, Texel).49pp.
- Dennison WC, Kirkman H (1996) Seagrass survival model. In: `Seagrass Biology: Proceedings of an International Workshop, Rottnest Island, Western Australia 25-29 January, 1996'. (Eds. J. Kuo, R. C. Phillips, D. I. Walker, and H. Kirkman.) (Faculty of Sciences, The University of Western Australia: Perth). pp341-344.
- Fry G, Heyward A, Wassenberg T, Taranto T, Stiegliz T and Colquhoun J (2008). Benthic Habitat surveys of potential LNG hub locations in the Kimberley region. A CSIRO and AIMS Joint Preliminary Report for the Western Australian Marine Science Institution, 18 July 2008.
- Gaskell, J. (2003). Engaging science education within diverse cultures. *Curriculum Inquiry*. **33**: 235-249.
- George, M., Innes, J., Ross, H. (2004). Managing sea country together: key issues for developing co-operative management for the Great Barrier Reef World Heritage Area. CRC Reef Research Centre Technical Report No 50, CRC Reef Research Centre Ltd, Townsville.
- Hardin, G. (1968). The tragedy of the commons. *Science, New Series* **162** (3859), 1243-1248.
- Hickey, R, Carew, R., Watkins, R, Piersma, T. and Pearson, G. 1998. Integrated GIS, Database Management, and Environmental Visualisation at Roebuck Bay, Western Australia. In: Adding a Spatial Dimension to Business, National conference, Fremantle WA, 353-362. Mapping Sciences Institute, Canberra.
- Johannes, R.E. (2002). The renaissance of community-based marine resource management in Oceania. *Annu. Rev. Ecol. Syst.* **33**: 317-340.
- Kirkman H. (1997). Seagrasses of Australia: State of Environment Technical Paper Series (Estuaries and the Sea), Department of Environment, Canberra. 36pp.
- Kuo J (2000). Taxonomic notes on *Halophila minor* and *H. ovata*. *Biol. Mar. Medit.* **7**(2): 79-82.
- Marsh, H. 1991. Our tropical siren. *Australian Geographic* **21**: 42-57.
- Masini, R.J., Sim, C.B. and Simpson, C.J. (2009) Protecting the Kimberley: A synthesis of scientific knowledge to support conservation management in the Kimberley region of Western Australia. Part A, Marine environments. Department of Environment and Conservation, Perth. 46pp.

- McKenzie, L.J. (2007). Seagrass-Watch: Proceedings of a Workshop for Monitoring Seagrass Habitats in the Kimberley Region, Western Australia. Department of Environment & Conservation - Kimberley District Office, Broome, 1st – 2nd September 2007 (Seagrass-Watch HQ, Cairns). 34pp.
- McKenzie, L.J., Campbell, S.J., Vidler, K.E. & Mellors, J.E. (2007) Seagrass-Watch: Manual for Mapping & Monitoring Seagrass Resources. (Seagrass-Watch HQ, Cairns) 114pp
- Middlebrook, R., Williamson, J.E. (2006). Social attitudes towards marine resource management in two Fijian villages. *Ecological Management & Restoration* **7** (2): 144-147.
- Piersma, T., Pearson, G., Hickey, B., Lavaleye, M. and Rogers, D. 2002. Southern Roebuck Bay Invertebrate and Bird Mapping 2002: SROEBIM-02. Unpublished preliminary research report prepared for the Department of Conservation and Land Management, Perth.
- Prince, R.I.T. (1986). Dugong in northern waters of Western Australia 1984. Technical Report No 7, (Department of Conservation and Land Management W.A., Perth). 38pp.
- Turnbull, J. (2004). Explaining complexities of environmental management in developing countries: lessons from the Fiji Islands. *The Geographical Journal* **170** (1), 64–77.
- Walker DI (1997) Marine Biological survey of the central Kimberley, Western Australia. Report to the National Estates Committee. 159pp.
- Walker, D.I. (2003). The seagrasses of Western Australia. In: Green EP, Short FT, Spalding MD (eds) *The World Atlas of Seagrasses: present status and future conservation* University of California Press, Chapter 10. pp109-118.
- Walker, D.I. and Prince R.I.T. (1987). Distribution and biogeography of seagrass species on the northwest coast of Australia. *Aquatic Botany* **29**: 19-32.
- Waycott, M, McMahon, K, Mellors, J., Calladine, A., and Kleine, D (2004) A guide to tropical seagrasses in the Indo-West Pacific. (James Cook University Townsville) 72pp.

### **Further reading:**

- den Hartog C. (1970). *The seagrasses of the world*. (North-Holland Publishing, Amsterdam). 293pp.
- Green EP. and Short FT (Eds) (2003). *World Atlas of Seagrasses*. Prepared by the UNEP World Conservation Monitoring Centre. (University of California Press, Berkeley. USA). 298pp.
- Lanyon JM, Limpus CJ and Marsh H. (1989). Dugongs and turtles: grazers in the seagrass system. In: *Biology of Seagrasses: A treatise on the biology of seagrasses with special reference to the Australian region*. (AWD Larkum, AJ McComb and SA Shepherd eds). (Elsevier: Amsterdam, New York). pp 610-34.
- Larkum AWD, Orth RJ and Duarte CM (2006). *Seagrasses: biology, ecology and conservation*. Springer, The Netherlands. 691 pp.
- Orth RJ, Carruthers TJB, Dennison WC, Duarte CM, Fourqurean JW, Heck Jr KL, Hughes AR, Kendrick GA, Kenworthy WJ, Olyarnik S, Short FT, Waycott M and Williams SL. (2006). A Global Crisis for Seagrass Ecosystems. *BioScience* **56** (12): 987-996.
- Lee Long, W. J., Coles, R. G. & McKenzie, L. J. (2000) Issues for seagrass conservation management in Queensland. *Pacific Conservation Biology* **5**, 321-328.
- Phillips, R.C, E.G Menez. (1988). *Seagrasses*. Smithsonian Institution Press, Washington, D.C. 104 pp.
- Poiner, I.R., Walker, D.I., and Coles, R.G. (1989). *Regional Studies - Seagrass of Tropical Australia*. In: *Biology of Seagrasses*. A.W.D. Larkum, A-J. McComb and S.A.Shepherd (Eds). Elsevier, Amsterdam, New York; 841 pp.
- Short, FT and Coles, RG. (Eds.) *Global Seagrass Research Methods*. Elsevier Science B.V., Amsterdam. 473pp.

## Useful web links

**Seagrass-Watch** Official Site [www.seagrasswatch.org](http://www.seagrasswatch.org)

**Western Australian Seagrass Webpage** Focuses on Western Australian research and provides some general information and links to international seagrass sites. [www.science.murdoch.edu.au/centres/others/seagrass/](http://www.science.murdoch.edu.au/centres/others/seagrass/)

**Seagrass Adventures** Interactive website designed by students from Bentley Park College in Cairns (Australia). Website includes games, puzzles and quizzes for students to learn about seagrass and their importance. [www.reef.crc.org.au/seagrass/index.html](http://www.reef.crc.org.au/seagrass/index.html)

**World Seagrass Association** A global network of scientists and coastal managers committed to research, protection and management of the world's seagrasses. [wsa.seagrassonline.org](http://wsa.seagrassonline.org)

**Seagrass Outreach Partnership** Excellent website on seagrass of Florida. Provides some background information on seagrasses and has a great section with educational products and Seagrass Activity Kit for schools. [www.flseagrass.org](http://www.flseagrass.org)

**Seagrass forum** A global forum for the discussion of all aspects of seagrass biology and the ecology of seagrass ecosystems. Because of their complex nature, discussion on all aspects of seagrass ecosystems is encouraged, including: physiology, trophic ecology, taxonomy, pathology, geology and sedimentology, hydrodynamics, transplanting/restoration and human impacts. [www.science.murdoch.edu.au/centres/others/seagrass/seagrass\\_forum.html](http://www.science.murdoch.edu.au/centres/others/seagrass/seagrass_forum.html)

**Reef Guardians and ReefEd** Education site of the Great Barrier Reef Marine Park Authority. Includes a great collection of resources about the animals, plants, habitats and features of the Great Barrier Reef. Also includes an on-line encyclopedia, colour images and videos for educational use, a range of free teaching resources and activities. [www.reefed.edu.au](http://www.reefed.edu.au)

**Integration and Application Network (IAN)** A website by scientists to inspire, manage and produce timely syntheses and assessments on key environmental issues, with a special emphasis on Chesapeake Bay and its watershed. Includes lots of helpful communication products such as fact sheets, posters and a great image library. [ian.umces.edu](http://ian.umces.edu)

**Reef Base** A global database, information system and resource on coral reefs and coastal environments. Also extensive image library and online Geographic Information System (ReefGIS) which allows you to display coral reef and seagrass related data on interactive maps. [www.reefbase.org](http://www.reefbase.org)

**UNEP - World Conservation Monitoring Centre** Explains the relationship between coral reefs, mangroves and seagrasses and contains world distribution maps. [www.unep-wcmc.org](http://www.unep-wcmc.org)

for more links, visit [www.seagrasswatch.org/links.htm](http://www.seagrasswatch.org/links.htm)





**We value your suggestions and any comments you may have to improve the Seagrass-Watch program.**

**Please complete the following statements in your own words**

*I found the Seagrass-Watch training to be .....*

.....  
.....

*What I enjoyed most about the training was.....*

.....  
.....

*It could have been better if.....*

.....  
.....

*I did not realize that.....*

.....  
.....

*Now I understand that.....*

.....  
.....

*In my area the types of seagrasses and habitats include.....*

.....  
.....  
.....

